

many
es between the
and a list of
ed in the text
ain legible
S REPORTS
its to Dfl. 77.00
concerned.
from the
ds.
r. The price of
ublisher
stored in a
otherwise,

TWISTOR THEORY: AN APPROACH TO THE QUANTISATION OF FIELDS AND SPACE-TIME

R. PENROSE

Birkbeck College, London, England

and

M.A.H. MacCALLUM

King's College, Cambridge, England



NORTH-HOLLAND PUBLISHING COMPANY - AMSTERDAM

TWISTOR THEORY: AN APPROACH TO THE QUANTISATION OF FIELDS AND SPACE-TIME

R. PENROSE

Birkbeck College, London, England

and

M.A.H. MacCALLUM

King's College, Cambridge, England

Received 9 June 1972

Contents:

Preface	243	3.2. Global twistors	269
0. Introduction	243	3.3. Quantisation	274
1. Preliminaries	245	4. Evaluation of scattering amplitudes	276
1.1. Conformal transformations	245	4.1. Introduction	276
1.2. Spinors	248	4.2. Rules for diagrams	282
1.3. Momentum and angular momentum	253	4.3. Evaluation of diagrams using elementary states	286
2. Twistors in flat space	256	4.4. Momentum state diagrams	292
2.1. Basic ideas; conformal invariance	256	5. Further developments	298
2.2. Twistor space and Minkowski geometry	258	5.1. Asymptotic twistors	298
2.3. Solutions of the zero-rest-mass field equations	261	5.2. Scattering off a fixed source	307
2.4. Quantisation	264	5.3. Potentials and massive fields	312
3. Twistors in curved space	266	References	314
3.1. Local twistors	267		

Abstract:

Twistor theory offers a new approach, starting with conformally-invariant concepts, to the synthesis of quantum theory and relativity. Twistors for flat space-time are the $SU(2,2)$ spinors of the twofold covering group $O(2,4)$ of the conformal group. They describe the momentum and angular momentum structure of zero-rest-mass particles. Space-time points arise as secondary concepts corresponding to linear sets in twistor space. They, rather than the null cones, should become "smeared out" on passage to a quantised gravitational theory. Twistors are represented here in two-component spinor terms. Zero-rest-mass fields are described by holomorphic functions on twistor space, on which there is a natural canonical structure leading to a natural choice of canonical quantum operators. The generalisation to curved space can be accomplished in three ways; i) local twistors, a conformally invariant calculus, ii) global twistors, and iii) asymptotic twistors which provide the framework for an S -matrix approach in asymptotically flat space-times. A Hamiltonian scattering theory of global twistors is used to calculate scattering cross-sections. This leads to twistor analogues of Feynman graphs for the treatment of massless quantum electrodynamics. The recent development of methods for dealing with massive (conformal symmetry breaking) sources and fields is briefly reviewed.

Single orders for this issue

PHYSICS REPORTS (Section C of PHYSICS LETTERS) 6, no. 4 (1972) 241-316.

Copies of this issue may be obtained at the price given below. All orders should be sent directly to the Publisher. Orders must be accompanied by check.

Single issue price Hfl. 25.- (\$ 8.00), postage included.

Preface

These notes given by R. Penrose in the summer of 1971, including sections on Astronomy.

0. Introduction

It is well known in physics. A more convincing synthesis of the notion of a new formalism and it is hoped provided. If the atmosphere for everyday life changed just a little, no final assessment encouraging for the use of collective. The last two regarded as a classical gravitational field many points in realistic and theoretical view that to err than simply apply should rather be replacing the classical seeking a way. In earlier work from the limit changing spin. satisfied by total $SU(2)$ spinors theory can be in spin and orbital of the twistor models of spac formalism, the plays a large part

Preface

These notes are an extended, revised and edited version of M. MacCallum's notes of a course given by R. Penrose at the Institute of Theoretical Astronomy, Cambridge, during the spring and summer of 1970. Additional material by R. Penrose on subsequent developments appears as a concluding section. Financial support for the lectures was provided by the Institute of Theoretical Astronomy.

0. Introduction

It is well known that there are a number of unsatisfactory features of our present ideas about physics. Among these are the infinite divergences of quantum field theory, the lack of a really convincing synthesis of quantum theory and general relativity, and perhaps also our dependence upon the notion of a continuum without any real physical evidence. Twistor theory is an attempt at a new formalism for the description of basic physical processes which has relevance to these problems and it is hoped that when the theory becomes more complete a new outlook on them will be provided. If the attempt is successful, it would of course have very wide implications for all of physics. For everyday purposes our present theories would naturally suffice but our viewpoint would be changed just as the development of relativity modified our view of Newtonian mechanics. Although no final assessment of twistor theory's success can yet be made the results have been sufficiently encouraging for us to feel it worthwhile preparing a reasonably up to date and unified account for the use of colleagues in different branches of physics.

The last two of the difficulties mentioned above are clearly related. If space-time is no longer regarded as a continuum, it will no longer be valid to think of either the quantum fields or the gravitational fields in the usual way. One can in fact argue [38] that to accept that there are as many points in 10^{-13} cm or even 10^{-1000} cm as there are in the entire universe is physically unrealistic and that our use of the continuum arises solely from its mathematical utility. We take the view that to encompass quantum theory and general relativity satisfactorily one needs to do more than simply apply some suitable quantisation technique to solutions of Einstein's equations. One should rather be thinking of quantising space-time itself. This should not be conceived as simply replacing the continuum by a discrete set of points (though this has been attempted) but rather as seeking a way of treating points as "smeared out" just as quantum theory smears out particles.

In earlier work [33, 37] it was shown that one could build up the notion of the Euclidean space from the limit of the interaction probabilities of a large network of particles quasi-statically exchanging spin. The Euclidean structure in this development arises from the combinatorial rules satisfied by total angular momentum in non-relativistic quantum mechanics. In the same way that SU(2) spinors provide a basis for the description of non-relativistic angular momentum, twistor theory can be used to describe relativistic angular momentum in a unified way, the concepts of spin and orbital angular momentum uniting together appropriately. The hope is that developments of the twistor picture will eventually enable us to construct Lorentzian manifolds to serve as models of space-time. Certainly points of space-time are dependent quantities in the twistor formalism, the twistors themselves playing the basic role. However the complex continuum still plays a large part. Indeed the complex numbers and holomorphic functions which are already

269
274
276
276
282
286
292
298
298
307
312
314

tary states

atum theory and
ormal group. They
secondary concepts
passage to a quan-
re described by
ice of canonical
ormally invariant
in asymptotically
. This leads to
opment of methods

sher. Orders

basic to modern particle physics now appear mixed up with the structure of space-time itself. Nevertheless, holomorphic functions have a certain "rigidity" suggestive of a possible underlying combinatorial structure.

The twistor theory is in fact largely based on ideas of conformal invariance, zero rest mass particles and conformally invariant fields being taken as a fundamental aspect of important parts of physics. In this respect twistor theory has a connection with current work by particle physicists, who have been exploring the implications of conformal invariance with considerable vigour [34, 39].

A twistor (of the simplest type) can be pictured "classically" as effectively a zero rest-mass particle in free motion, where the particle may possess an intrinsic spin, and also a "phase" which can be realized as a kind of polarization plane. Such twistors form an eight-real-dimensional manifold, which can be described in a natural way as a vector space of four complex dimensions. This vector space (twistor space) in effect replaces the space-time as the background in terms of which physical phenomena are to be described. Space-time points can then be reconstructed from the twistor space (being represented as certain linear subspaces), but they become secondary to the twistors themselves. Furthermore, when general relativity and quantum theory both become involved, it is to be expected that the concept of a space-time point should cease to have precise meaning within the theory. In effect, the space-time points become "smeared" by the uncertainty principle (rather than the light cones becoming "smeared" and the points not — which has been a more usual viewpoint).

As the theory stands it does not provide a formulation of a quantised general relativity; quantized gravitational interactions have not yet been successfully incorporated into the theory. Nor has a full treatment of particles with non-vanishing rest-mass emerged. On the other hand, the theory appears to give correct answers for scattering processes involving massless charged particles and photons (i.e. high energy limit of quantum electrodynamics) and it may even yield some new insights into the nature of the electromagnetic interaction. The theory so far appears to be successful in avoiding divergences, i.e. the calculations that have been carried out do not lead to infinities in the same way as does the conventional formalism and it seems that such infinities should be absent altogether. It is hoped that when the theory becomes more complete, this feature will be retained.

The difficulties confronting the theory in respect of gravitational interactions and rest-mass appear to be related to the fact that these are things which *break conformal invariance*. Massless particles and electromagnetic interactions, on the other hand, *are* conformally invariant concepts. The basic formalism exhibits manifest conformal invariance, so if conformal invariance is to be broken, this must apparently be done explicitly, with the aid of auxiliary elements which do not share in the invariance. One possible method of incorporating such elements is suggested by the work described in section 5.3. The essential act of faith on which the utility of the twistor formalism depends, is that it should be useful to isolate the conformally non-invariant aspects of physics from the conformally invariant ones, and that having done this, a large and important body of physical processes will be seen as possessing conformal invariance.

Twistors (that is to say, the original flat-space twistors about which these notes are mainly concerned) are actually the reduced spinors for the proper pseudo-orthogonal group $SO(2,4)$ which is locally isomorphic with, and 2-1 homomorphic with, the restricted conformal group of flat space-time. They form a representation space for the pseudo-unitary group $SU(2,2)$, this in turn being

locally isomorphic objects with four group of flat space

role in this theory. One of the most holomorphic (i.e. symmetry of space-time and holomorphic seems, therefore, important constituents suggesting that conformal space-time itself. I (wave equation, W equations) all emerge in a contour integral. The usual splitting of terms of the position effect of uniting vectors seem to play in physics.

The present notation is not solved in the theoretical formalism and the Feynman diagrams describing conventional (Feynman) some extent by graphs constitute another insights into the nature of stands. For example, a different point of view - distance in the twist processes. This we root" of the structure.

Preliminaries

1.1. Conformal transformations. There is a certain group which is both given the structure of the first of these transformations.

$$g_{ab} \rightarrow \tilde{g}_a$$

See footnote on the next page.

locally isomorphic and 2-1 homomorphic with $SO(2,4)$. Thus, the simplest twistors are four-valued objects with four complex components, which are acted upon by the 15 parameter conformal group of flat space-time. The four-valuedness of twistors has not yet played any very important role in this theory, however.

One of the most striking features of twistor theory is the way in which complex numbers and holomorphic (i.e. complex analytic) structure emerge as concepts intimately involved in the geometry of space-time. We have become accustomed to the very basic role which complex numbers and holomorphic functions play in quantum theory, particularly that of elementary particles. It seems, therefore, that complex numbers are (at least at our present level of understanding) a very important constituent of the structure of physical laws. The twistor theory carries this further in suggesting that complex numbers may also be very basically involved in defining the nature of space-time itself. In addition, we shall see that the zero rest-mass field equations for each spin (wave equation, Weyl neutrino equation, Maxwell free-field equations, linearized Einstein equations) all emerge in a very simple way from the complex structure of twistor space, being obtained as contour integrals of holomorphic functions of twistors. The twistor picture "geometrises" the usual splitting of field amplitudes into positive and negative frequency parts by describing this in terms of the position of singularities of holomorphic functions. Thus the twistor formalism has the effect of uniting various aspects of the role, both quantum and classical, that complex numbers seem to play in physics.

The present notes should be regarded as to some extent provisional. Many problems remain to be solved in the theory. Even the difficulties involved in merely translating between the twistor formalism and the conventional formalism constitute a serious stumbling block. The twistor scattering diagrams described in section 4 do not always appear to be directly translatable into conventional (Feynman) terms and this leads to difficulties in interpretation. One must proceed to some extent by guesswork, but here severe problems of actually computing the twistor diagrams constitute another stumbling block. Nevertheless, despite these difficulties, we feel that some new insights into the nature of physical processes may possibly be discernable even in the theory as it stands. For example, if the twistor diagrams of section 4 are to be taken seriously from the physical point of view — and it is tempting to think that they can be — then there may be some significance in the twistor lines representing a kind of "half particle" which can be exchanged in virtual processes. This would appear to be related to the fact that a twistor is really a kind of "square root" of the structure of a zero rest-mass particle.

1. Preliminaries

1.1. Conformal transformations

There is a certain confusion in the literature owing to the fact that two quite distinct concepts are both given the name "conformal transformation".

The first of these, which we shall refer to (cf. [34]) as a *conformal rescaling*, consists solely of replacement¹

$$g_{ab} \rightarrow \hat{g}_{ab} = \Omega^2 g_{ab} \quad (1.1)$$

¹see footnote on the next page.

of the space-time metric g_{ab} by a conformally-related one \hat{g}_{ab} , Ω being a smooth positive scalar field on the underlying manifold. Thus the interval ds is transformed to $d\hat{s} = \Omega ds$. If g_{ab} is a flat metric, then \hat{g}_{ab} will in general not be flat, though it will of course be conformally flat. The conformal rescalings of a given space-time form an infinite-parameter Abelian group. The points of the space-time are unaffected by a conformal rescaling. The null cones, and, therefore, the causal structure of the space-time, are also unchanged.

The other type of conformal transformation is what we shall call a *conformal mapping*. This is a smooth mapping μ which carries each point of a space-time N to a point of some space-time \tilde{N} in such a way that the metric on \tilde{N} induced by μ from that of N is a conformal rescaling of the original metric on \tilde{N} . In other words the map μ preserves null cone structure.

Conformal mappings of Minkowski space² M' to itself have a particular interest. These include the Poincaré transformations, which are metric-preserving, and the simple overall dilations, whose corresponding rescaling multiplies the metric at each point by a constant factor. The remainder are generated by the (involuntary) inversions

$$\hat{x}^a = -x^a (x^b x_b)^{-1}, \quad x^a = -\hat{x}^a (\hat{x}^b \hat{x}_b)^{-1} \tag{1.2}$$

which are a 4-parameter set since the choice of origin is arbitrary. These transformations preserve the time sense but involve spatial reflection. They are conformal mappings since the induced and original metrics are related by

$$d\hat{s}^2 = d\hat{x}^a d\hat{x}_a = dx^a dx_a / (x^b x_b)^2 = \Omega^2 ds^2. \tag{1.3}$$

However, these transformations do not involve only the points of M' , because the null cone of the origin is sent to infinity. We therefore introduce compactified Minkowski space M , which consists of M' together with a closed null cone at infinity. We may picture the structure in terms of two cones joined base to base, the interior being M' and the two bounding cones being identified along opposite generators with future sense preserved (see fig. 1). (Thus the "equator" I_0 must be considered as a single point.) For fuller discussion of the structure of M , see [2-4]. Note that one can consider the equations (1.2) as expressing a coordinate change, rather than a point transformation, on M ; and that the null cone at infinity is on the same footing as any other null cone in M as far as conformal mapping symmetry is concerned (see [3]). In consequence of the latter, the concept of radiation is not conformally invariant, since it depends on knowing where infinity is.

The conformal mapping group of M is of 15 parameters (and non-abelian). We shall here concern ourselves with the restricted conformal group, i.e. the subgroup of mappings connected with the

¹Footnote from preceding page. We adopt throughout these notes the "abstract index" convention [1, 2]. Abstract indices are non-numerical and serve only as organisational markers enabling the basically coordinate-free operations of contraction, index-permutation, outer multiplication, addition and complex conjugation to be expressed in a transparent, yet frame-independent, way. Latin and Greek indices will be used in this abstract way, while Gothic and Hebrew indices will be used for the corresponding "normal" indices (i.e. to represent the components in some particular frame). Latin lower case letters will be abstract tensor indices, upper case Latin letters abstract spinor indices and Greek letters abstract twistor indices. Thus Gothic lower case (tensor) and Hebrew (twistor) letters will range from 0 to 3, while Gothic upper case (spinor) letters range from 0 to 1. In all cases round brackets surrounding indices denote symmetrisation, square brackets skew-symmetrisation.

²Minkowski space is simply flat space-time ("space-time" meaning a pseudo-Riemannian Hausdorff manifold of signature -2 and dimension 4). Coordinates x^a used without definition are the natural pseudo-Cartesian ("flat") ones. We can also use x^a with an abstract index to denote the position vector with respect to some origin. Also ∇_a denotes the covariant derivative (or gradient) so $\nabla_a x^b = \delta_a^b$. Thus in flat coordinates $\nabla_a = \partial/\partial x^a$.

Fig. 1. Compactified Minkowski space, where I^+ , I^- are identified along opposite generators.

identity map³. It is a conformal mapping with space reflection, and is pseudo-orthogonal and pseudo-unitary on the tangent space. The infinitesimal generators are given, for infinitesimal transformations,

$$x^a \rightarrow x^a + \xi^a$$

The vectors ξ_a must satisfy

$$\nabla_{(a} \xi_{b)} = 0$$

The general solution is

$$\xi_a = S_{ab} x^b$$

where $S_{ab} = S_{[ab]}$ is the generator of the dilations (15 parameters). (The correct use of the Minkowski metric makes the Minkowski

$$ds^2 = z^2 dx^a dx_a$$

Questions of conformal rescalings rather than conformal mappings are invariant if it is possible to find a conformal mapping which makes the Minkowski metric conformally flat.

Thus we will not be concerned with conformal mappings for an introduction to which physicists accustomed to the use of the Minkowski metric

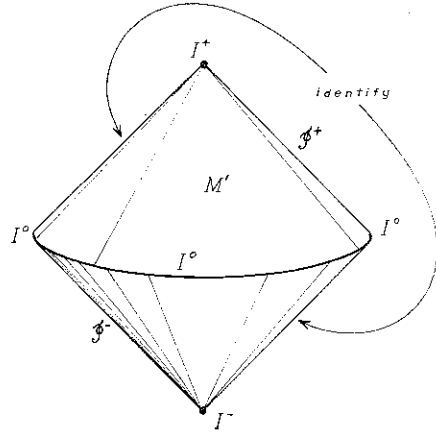

Fig. 1. Compactified Minkowski space \$M\$. \$I^0, I^+, I^-\$ are points at spatial infinity, future time infinity and past time infinity respectively, while \$\tilde{I}^+, \tilde{I}^-\$ are future and past null infinity cones (cf. [3]). The compactified space has \$I^0, I^+, I^-\$ identified and \$\tilde{I}^-, \tilde{I}^+\$ identified along opposite generators. For typographical reasons, "\$I\$" replaces the more usual script \$I\$ depicted in figs. 1 and 40.

(1.2)

identity map³. This does not include the actual mappings (1.2) but does include their products with space reflections. It is 2-1 covered by (and so locally isomorphic with) the six-dimensional pseudo-orthogonal group \$SO(2,4)\$ which in turn is 2-1 covered by \$SU(2,2)\$, a group of unimodular pseudo-unitary matrices [6].

(1.3)

The infinitesimal conformal motions⁴ are described by the conformal Killing vectors \$\xi^a\$ and are given, for infinitesimal \$\epsilon\$, by

$$x^a \rightarrow x^a + \epsilon \xi^a.$$

The vectors \$\xi_a\$ must satisfy

$$\nabla_{(a} \xi_{b)} = \frac{1}{4} g_{ab} (\nabla_c \xi^c). \tag{1.4}$$

The general solution of this is

$$\xi_a = S_{ab} x^b + T_a + Q_a (x^c x_c) - 2x_a (x^c Q_c) + R x_a \tag{1.5}$$

where \$S_{ab} = S_{[ab]}\$ generate the Lorentz rotations (6 parameters), \$T_a\$ the translations (4 parameters), \$R\$ the dilations (1 parameter) and \$Q_a\$ the so-called "uniform acceleration" transformations [8] (4 parameters). (This terminology is rather misleading, however, and will be avoided here. A more correct use of the terminology "uniform acceleration" is for a coordinate transformation which makes the Minkowski metric take the form

$$ds^2 = z^2 dt^2 - dx^2 - dy^2 - dz^2 \quad \text{cf. [2].})$$

Questions of conformal invariance are handled most easily within the framework of conformal rescalings rather than conformal mappings. A physical theory will be said to be *conformally invariant* if it is possible to attach conformal weights to all the quantities appearing in the theory in

Thus we will not be concerned with reflections. For some discussion of reflections in twistor theory see [5]. For an introduction to the description of Lie groups of transformations of a manifold in terms of the generating vectors (with which physicists accustomed to considering Lie groups only in terms of their representations may be unfamiliar) see e.g. [7].

such a way that all field equations are preserved under conformal rescalings. (A tensor or spinor $A \dots$ is said to have conformal weight r if we are to make the replacement $A \dots \rightarrow \hat{A} \dots = \Omega^r A \dots$ under the conformal rescaling $g_{ab} \rightarrow \hat{g}_{ab} = \Omega^2 g_{ab}$.) A flat space theory which is Poincaré invariant and also conformally invariant in this sense, will then be invariant under the 15-parameter conformal group. This is because the Poincaré motions of Minkowski space become conformal motions according to any other conformally rescaled flat metric. Conformal motions obtainable in this way are sufficient to generate the full conformal group. But the type of conformal invariance described above is really more general than this since the conformal rescalings need not apply to flat space-time at all or even to conformally flat space-times.

In order to establish conformal invariance of a theory, one needs to know how to transform the (covariant) derivative operator under conformal rescaling. Remarkably enough, this is rather simple within the two-component spinor formalism than within the tensor formalism. Since two-component spinors will also play an essential role in other aspects of twistor theory, we will next briefly summarise the relevant notation and methods.

1.2. Spinors

The essential fact on which the 2-component spinor calculus is based is the local isomorphism between the Lorentz group and the group $SL(2, \mathbb{C})$ of complex unimodular 2×2 matrices (which is the covering group of the identity-connected component of the Lorentz group). It should be noted that this does not mean that spinors can only be used in flat space, since it is possible to use this isomorphism locally in curved space-time [9, 40].

Representing the Minkowski components u^a of a world vector u^a according to the matrix scheme

$$u^a = (u^0, u^1, u^2, u^3) \leftrightarrow u^{AA'} = \begin{pmatrix} u^{00'} & u^{01'} \\ u^{10'} & u^{11'} \end{pmatrix} = \frac{1}{\sqrt{2}} \begin{pmatrix} u^0 + u^1 & u^2 + iu^3 \\ u^2 - iu^3 & u^0 - u^1 \end{pmatrix} \quad (1.6)$$

we find that when the components u^a undergo a restricted Lorentz transformation L the $u^{AA'}$ undergo

$$u^{AA'} \rightarrow \begin{pmatrix} \alpha & \beta \\ \gamma & \delta \end{pmatrix} \begin{pmatrix} u^{00'} & u^{01'} \\ u^{10'} & u^{11'} \end{pmatrix} \begin{pmatrix} \bar{\alpha} & \bar{\gamma} \\ \bar{\beta} & \bar{\delta} \end{pmatrix} \quad (1.7)$$

where $\alpha, \beta, \gamma, \delta$ are complex and their matrix has unit determinant, i.e. $\alpha\delta - \beta\gamma = 1$. The hermiticity of $u^{AA'}$, i.e. reality of u^a , is preserved and so is

$$\{(u^0)^2 - (u^1)^2 - (u^2)^2 - (u^3)^2\} = 2 \det(u^{AA'}). \quad (1.8)$$

We can express (1.7) as

$$u^{AA'} \rightarrow S(L)^A_{\ B} u^{BB'} \bar{S}(L)^{B'}_{\ A'} \quad (1.9)$$

where $S(L) \in SL(2, \mathbb{C})$. Primed and unprimed indices must be treated as essentially different as regards contractions and permutations, but they are related to each other by complex conjugation which converts a primed index into an unprimed one and vice versa.

⁵ I.e. unprimed capital Gothic superfixes represent components transforming under the representation $S(L)$; primed superfixes under the complex conjugate representation $\bar{S}(L)$; and primed and unprimed suffixes under the transposed inverses of $S(L), \bar{S}(L)$ respectively.

The correspondence (1.6) shows how one may relate tensor and spinor components according to a standard scheme, but there is nothing special about this particular correspondence. From the point of view of the abstract index notation¹, the essential feature is that each abstract tensor index (four-dimensional) is to be equated with a pair of (two-dimensional) spinor indices, one primed and one unprimed. Thus the abstract tensor indices $a, b, c, \dots, a_0, b_0, \dots, a_1, \dots$, may be expressed as $a = AA', b = BB', \dots, a_0 = A_0A'_0, \dots$ and we can write

$$u^a = u^{AA'}$$

(The reader who prefers to retain a component description such as that of (1.6) can re-express our equations in these terms by use of the Infeld-van der Waerden symbols $\sigma^a_{\alpha\beta}, \sigma^a_{\alpha'\beta'}$ [40].) Also (cf. (1.8))

$$g_{ab} = \epsilon_{AB}\epsilon_{A'B'}, \quad g^{ab} = \epsilon^{AB}\epsilon^{A'B'} \quad (1.10)$$

where the ϵ 's are skew-symmetrical with $\epsilon_{A'B'} = \overline{\epsilon_{AB}}, \epsilon^{A'B'} = \overline{\epsilon^{AB}}$ (i.e. their coordinate representations under (1.6) are $\begin{pmatrix} 0 & 1 \\ -1 & 0 \end{pmatrix}$). We use ϵ 's to raise and lower indices, thus

$$\xi_B = \xi^A \epsilon_{AB}; \quad \xi^A = \epsilon^{AB} \xi_B; \quad \eta_{B'} = \eta^{A'} \epsilon_{A'B'}; \quad \eta^{A'} = \epsilon^{A'B'} \eta_{B'}. \quad (1.11)$$

The tensor and spinor "Kronecker deltas" will be written g_b^a and $\epsilon_{A'}^B, \epsilon_{A'}^{B'}$, respectively. Thus

$$g_a^b = \epsilon_A^B \epsilon_{A'}^{B'}$$

$$\chi^{...a} \cdot g_a^b = \chi^{...b} \cdot \cdot \cdot, \quad \psi_{...A} \cdot \epsilon_B^A = \psi_{...B} \cdot \cdot \cdot, \quad \theta \cdot \cdot \cdot \cdot \epsilon_{A'}^{B'} = \theta \cdot \cdot \cdot \cdot \cdot \cdot \cdot$$

A complex null vector $u^a (u_b u^b = 0)$ has a spinor form

$$u^{AA'} = \xi^A \eta^{A'}$$

since the matrix of components $u^{AA'}$ has rank ≤ 1 , cf. (1.8)⁶. If u^a is real, then⁷

$$u^{AA'} = \pm \xi^A \bar{\xi}^{A'}. \quad (1.12)$$

The plus sign occurs if u^a is future-pointing and the minus if u^a is past-pointing. Note that $\xi^A \xi_A = 0$ (as ϵ_{AB} is skew) so that $u^a u_a = 0$ follows directly from (1.12). Conversely if $\xi^A \xi_A = 0$ then ξ^A is a scalar multiple of ζ^A (or $\zeta_A = 0$).

A spinor ξ_A contains more information than the corresponding null vector given by (1.12). A non-zero spinor has a geometrical interpretation, up to an essential sign ambiguity, as a *null flag* [1, 10]. This consists of the corresponding null vector u^a ("flagpole") and a null 2-plane ("flag

and other simplifying features, arise from the two-dimensionality of the vector space of spinors. As another example, any spinor α_{AB} can be expressed as a sum of a symmetrised outer-product of one-index spinors and a skewed outer-product. We will write conjugate of a quantity as

$$\overline{\chi^{A'}_{BC'D'}} = \bar{\chi}^A_{B'C'D'}$$

except in the case of $\epsilon_{A'B'}$ etc. and basis spinors σ^A, ι^B where the bar will be omitted. Many authors omit the bar on the right-hand symbol but we retain it for the sake of clarity and notational consistency and in addition because of the flexibility it allows in the placing of indices, i.e. we can write $\phi_{AA'BB'} = \phi_{ABA'B'} = \phi_{A'B'AB}$ without confusion while $\bar{\phi}_{AA'BB'} = \bar{\phi}_{A'B'AB} = \bar{\phi}_{ABA'B'}$.

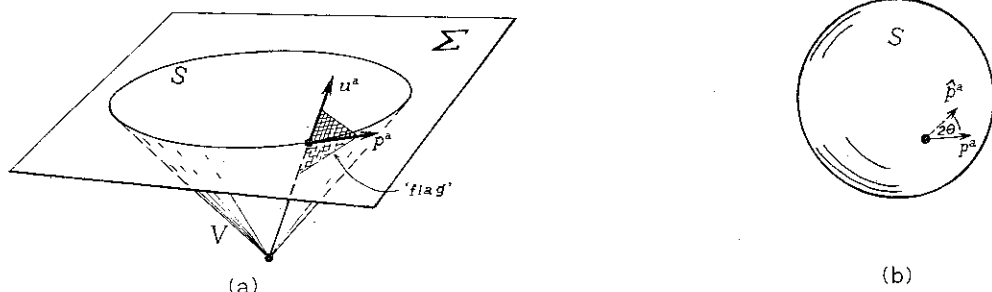

(a) One spatial dimension suppressed.

(b) Time dimension suppressed.

Fig. 2. (a) The spinor ξ_A defines a "null flag". This may be pictured as a polarisation vector tangent to the "celestial sphere" S. (b) shows how p^b is rotated when the phase of ξ_A is altered.

plane") element which contains and is orthogonal to the flagpole. This latter is defined by the bivector

$$F_{ab} = u_{[a}p_{b]} = \epsilon_{AB}\bar{\xi}_A\xi_{B'} + \epsilon_{A'B'}\xi_A\xi_B, \tag{1.13}$$

where $p_a = 2(\xi_A\bar{\lambda}_{A'} + \lambda_A\bar{\xi}_{A'})$ for some λ_A with $\xi_A\lambda^A = 1$. When the phase of ξ_A is altered (i.e. $\xi_A \rightarrow e^{i\theta}\xi_A$) the vector u_a is unaltered, while p_b turns through an angle 2θ . We may consider a spacelike hyper-plane Σ intersecting the null cone V , of a point O , in S (a 2-sphere). ξ_A then describes a point on S , and a vector tangent to S which defines a polarisation direction. As θ varies this polarisation vector sweeps out the 2-plane tangent to S , and performs one revolution through 2π as θ changes by π (see fig. 2).

Our (covariant) derivative operator $\nabla_a = \nabla_{AA'}$ satisfies

$$\nabla_a \epsilon_{BC} = 0, \quad \nabla_a \epsilon_{B'C'} = 0$$

(whence $\nabla_a g_{bc} = 0$), and

$$\nabla_a \nabla_b \phi = \nabla_b \nabla_a \phi.$$

In curved space-time, we have the relation

$$(\nabla_{AA'}\nabla_{BB'} - \nabla_{BB'}\nabla_{AA'})\xi_C = \Psi_{ABCD}\xi^D\epsilon_{A'B'} - 2\Lambda\xi_{(A}\epsilon_{B)C}\epsilon_{A'B'} + \Phi_{CDA'B'}\xi^D\epsilon_{AB}$$

where the curvature spinors Ψ_{ABCD} , $\Phi_{ABC'D'}$, Λ have the symmetries

$$\Psi_{ABCD} = \Psi_{(ABCD)}, \quad \Phi_{ABC'D'} = \bar{\Phi}_{ABC'D'} = \Phi_{(AB)(C'D')}, \quad \Lambda = \bar{\Lambda} \tag{1.15}$$

and are related to the curvature tensor R_{abcd} (with sign convention $(\nabla_a\nabla_b - \nabla_b\nabla_a)V_d = R_{abcd}V_c$) by

$$R_{abcd} = \Psi_{ABCD}\epsilon_{A'B'}\epsilon_{C'D'} + \epsilon_{AB}\epsilon_{CD}\bar{\Psi}_{A'B'C'D'} + 2\Lambda(\epsilon_{AC}\epsilon_{BD}\epsilon_{A'B'}\epsilon_{C'D'} + \epsilon_{AB}\epsilon_{CD}\epsilon_{A'D'}\epsilon_{B'C'}) + \epsilon_{A'B'}\Phi_{ABC'D'}\epsilon_{CD} + \epsilon_{AB}\Phi_{CDA'B'}\epsilon_{C'D'}. \tag{1.16}$$

We thus have

R. Penrose
 Φ
 (where R_{ab}
 Ψ
 where C_{abcd}
 dition for th
 We also ir
 η^a
 defined by τ
 equivalent is
 η_a
 Now we c
 we take
 \hat{e}_A
 We have $\hat{\nabla}_a\phi$
 $\hat{\nabla}$
 $\hat{\nabla}$
 where
 τ_a
 When ∇_a act
 above schem
 $\hat{\nabla}_c$
 by the 2-dim
 $\hat{\nabla}_a$
 using $\chi_{...AB}$.
 transformatio

$$\Phi_{ABA'B'} = -\frac{1}{2}R_{ab} + \frac{1}{8}Rg_{ab}, \quad \Lambda = R/24$$

(where $R_{ab} = R^c{}_{acb}$, $R = R^a{}_a$) and

$$\Psi_{ABCD}\epsilon_{A'B'}\epsilon_{C'D'} + \epsilon_{AB}\epsilon_{CD}\bar{\Psi}_{A'B'C'D'} = C_{abcd}$$

where C_{abcd} is Weyl's conformal curvature tensor, whose vanishing is a necessary and sufficient condition for the space-time to be conformally flat.

We also introduce, for future use, the completely skew tensor

$$\eta^{abcd} = \eta^{[abcd]}$$

defined by $\eta^{0123} = (\sqrt{-g})^{-1}$, so that $\eta_{0123} = -\sqrt{-g}$, in a right-handed coordinate system. Its spinor equivalent is given by

$$\eta_{abcd} = i\epsilon_{AD}\epsilon_{BC}\epsilon_{A'C'}\epsilon_{B'D'} - i\epsilon_{AC}\epsilon_{BD}\epsilon_{A'D'}\epsilon_{B'C'} \quad (1.17)$$

Now we can discuss how conformal rescalings affect spinors. Under the rescaling $g_{ab} \rightarrow \hat{g}_{ab} = \Omega^2 g_{ab}$ we take

$$\hat{\epsilon}_{AB} = \Omega\epsilon_{AB}, \quad \hat{\epsilon}_{A'B'} = \Omega\epsilon_{A'B'}, \quad \hat{\epsilon}^{AB} = \Omega^{-1}\epsilon^{AB}, \quad \hat{\epsilon}^{A'B'} = \Omega^{-1}\epsilon^{A'B'} \quad (1.18)$$

We have $\hat{\nabla}_a \phi = \nabla_a \phi$ when ∇_a acts on a scalar. When ∇_a acts on spinors we have

$$\begin{aligned} \hat{\nabla}_{AA'}\xi_B &= \nabla_{AA'}\xi_B - \Upsilon_{BA'}\xi_A, & \hat{\nabla}_{AA'}\eta_{B'} &= \nabla_{AA'}\eta_{B'} - \Upsilon_{AB'}\eta_{A'} \\ \hat{\nabla}_{AA'}\xi^B &= \nabla_{AA'}\xi^B + \epsilon_A{}^B\Upsilon_{CA'}\xi^C, & \hat{\nabla}_{AA'}\eta^{B'} &= \nabla_{AA'}\eta^{B'} + \epsilon_{A'}{}^{B'}\Upsilon_{AC'}\eta^{C'} \end{aligned} \quad (1.19a)$$

where

$$\Upsilon_a = \Omega^{-1}\nabla_a\Omega \quad (1.19b)$$

When ∇_a acts on spinors of higher valence we simply treat each index in turn according to the above scheme (so there is one term involving Υ_a for each index). For example,

$$\begin{aligned} \hat{\nabla}_{CC'}\hat{\epsilon}_{AB} &= \hat{\nabla}_{CC'}(\Omega\epsilon_{AB}) \\ &= (\nabla_{CC'}\Omega)\epsilon_{AB} + \Omega(\nabla_{CC'}\epsilon_{AB}) + (\nabla_{AC'}\Omega)\epsilon_{CB} + (\nabla_{BC'}\Omega)\epsilon_{AC} \\ &= 3\epsilon_{[AB}\nabla_{C]C'}\Omega = 0 \end{aligned}$$

(by the 2-dimensionality of spinor space). The covariant derivative of a vector transforms as

$$\begin{aligned} \hat{\nabla}_a V_b &= \hat{\nabla}_{AA'}V_{BB'} = \nabla_{AA'}V_{BB'} - \Upsilon_{BA'}V_{AB'} - \Upsilon_{AB'}V_{BA'} \\ &= \nabla_a V_b - \Upsilon_a V_b - \Upsilon_b V_a + (\Upsilon_{AA'}V_{BB'} + \Upsilon_{BB'}V_{AA'} - \Upsilon_{BA'}V_{AB'} - \Upsilon_{AB'}V_{BA'}) \\ &= \nabla_a V_b - \Upsilon_a V_b - \Upsilon_b V_a + \epsilon_{AB}\epsilon_{A'B'}\Upsilon_{CC'}V^{CC'} \\ &= \nabla_a V_b - \Upsilon_a V_b - \Upsilon_b V_a + g_{ab}(\Upsilon_c V^c) \end{aligned} \quad (1.20)$$

(using $\chi_{...AB...} - \chi_{...BA...} = \epsilon_{AB}\epsilon^{CD}\chi_{...CD...}$). Note that this generates the transform under conformal transformations of ∇_a applied to tensor indices, as (1.19) does for spinors.

Using this information we find the following transformation laws for the curvature

$$\hat{\Psi}_{ABCD} = \Psi_{ABCD}$$

and

$$\hat{P}_{ABC'D'} = P_{ABC'D'} - \nabla_{AC'}\Upsilon_{BD'} + \Upsilon_{AD'}\Upsilon_{BC'} \tag{1.21}$$

where

$$P_{ABA'B'} = \Phi_{ABA'B'} - \Lambda \epsilon_{AB}\epsilon_{A'B'} = \frac{1}{12} Rg_{ab} - \frac{1}{2} R_{ab}.$$

The Bianchi identities $\nabla_{[a}R_{bc]de} = 0$, which are equivalent to

$$\nabla^a C_{abcd} = 2 \nabla_{[c}P_{d]b},$$

become

$$\nabla_{A'}^D \Psi_{ABCD} = -\nabla_{(C}^{B'} P_{A)BA'B'} \tag{1.22}$$

which in empty space-time ($P_{ab} = R_{ab} = 0$) simplifies to

$$\nabla^{AD'} \Psi_{ABCD} = 0. \tag{1.23}$$

Finally let us consider some conformally-invariant theories. For example, Maxwell's equations

$$\nabla_a F^{ba} = 4\pi J^b \text{ and } \nabla_{[a} F_{bc]} = 0$$

are conformally invariant if we set $\hat{F}_{ab} = F_{ab}$ and $\hat{J}_a = \Omega^{-2} J_a$ (so $\hat{F}^{ab} = \Omega^{-4} F^{ab}$; $\hat{j}^a = \Omega^{-4} J^a$). That is to say we get

$$\hat{\nabla}_a \hat{F}^{ba} = 4\pi \hat{J}^b \text{ and } \hat{\nabla}_{[a} \hat{F}_{bc]} = 0.$$

This may be verified in various ways, e.g. by using the tensor formula for $\hat{\nabla}_a$ above, or by using the spinor formulae applied to the spinor version

$$\nabla_{B'}^A \phi_{AB} = -2\pi J_{BB'} \tag{1.24}$$

of Maxwell's equations, where

$$F_{ab} = \phi_{AB}\epsilon_{A'B'} + \epsilon_{AB}\bar{\phi}_{A'B'}$$

with $\phi_{AB} = \phi_{(AB)}$, $\hat{\phi}_{AB} = \Omega^{-1} \phi_{AB}$. When $J_a = 0$, (1.24) becomes a particular case of the zero-rest-mass free-field equations for spin $\frac{1}{2}n$

$$\nabla^{AP'} \phi_{AB\dots L} = 0 \tag{1.25}$$

where $\phi_{AB\dots L}$ is symmetric with n indices (see [12]). If $n = 0$ we adopt the second-order equation

$$(\nabla_a \nabla^a + \frac{1}{6} R)\phi = 0. \tag{1.26}$$

For each n , these equations are conformally invariant if $\hat{\phi}_{AB\dots L} = \Omega^{-1} \phi_{AB\dots L}$ as is readily verified using (1.19) etc. [13]. The case $n = 4$ has particular interest since the tensor

R. Pe
K
defined fro
K
K
and represe
g,
where η_{ab} is
locally⁸ the
satisfies (1.
while \hat{K}_{abcd}
Finally w
tensors are
energy. We
It turns out
the positive
 ∇
have the otl
of indices o
helicity.
For exam
spinor form
F
and ϕ_{AB} , θ_A
 ϕ
 θ
The ϕ_{AB} thu
left-handed.
energy part
part of the s
1.3. Momen
In special
and a total e
 $\tilde{p}^a = P$
for an empty

$$K_{abcd} = \phi_{ABCD} \epsilon_{A'B'} \epsilon_{C'D'} + \epsilon_{AB} \epsilon_{CD} \bar{\phi}_{A'B'C'D'}$$

defined from a solution of (1.25) in Minkowski space, satisfies

$$(1.21) \quad \begin{aligned} K_{abcd} &= K_{[ab][cd]} = K_{cdab}, & K_{a|bcd|} &= 0, \\ K^a{}_{bcd} &= 0, & \nabla^a K_{abcd} &= 0 \quad (\text{whence } \nabla_{[a} K_{bc]de} = 0) \end{aligned} \quad (1.27)$$

and represents a source-free gravitational field in the linearised theory. In this it is assumed that

$$g_{ab} = \eta_{ab} + \epsilon h_{ab}$$

where η_{ab} is the Minkowski metric, ϵ is infinitesimal and h_{ab} is some symmetric tensor. K_{abcd} is locally⁸ the Weyl (or in empty space, Riemann) tensor for some metric of this form, provided it satisfies (1.27). It should be noted that conformal rescaling of the metric gives $\hat{C}_{abcd} = \Omega^{-2} C_{abcd}$ while $\hat{K}_{abcd} = \Omega^{-1} K_{abcd}$. For further details of spinor calculus see [2, 9, 15, Pirani in 35].

(1.22) Finally we note that to describe states in quantum mechanical systems, complex vectors and tensors are used. If the operator $i\hbar \partial/\partial t$ has positive eigenvalue, the quantum state has positive energy. We will describe these and the corresponding classical states as having positive frequency.

(1.23) It turns out the solutions of (1.25) with positive energy represent negative helicity particles and the positive energy solutions of the conjugate equation

$$\nabla^A P \theta_{A'B'...L'} = 0 \quad (1.28)$$

have the other helicity. This essential difference reappears in section 2.3. Raising and lowering of indices only alters the conformal weight, but complex conjugation of the spinor reverses the helicity.

For example a free photon wave function is described by a complex F_{ab} . When translated into spinor form this gives rise to independent spinors $\phi_{AB}, \theta_{A'B'}$ by

$$F_{ab} = \epsilon_{AB} \phi_{AB} + \epsilon_{AB} \theta_{A'B'}$$

and $\phi_{AB}, \theta_{A'B'}$ satisfy respectively (1.25) and (1.28). Considering a plane wave, we find

$$(1.24) \quad \begin{aligned} \phi_{AB} &= \alpha_A \alpha_B \exp \{-i(\alpha_P \bar{\alpha}_{P'} \cdot X^{PP'})\} \\ \theta_{A'B'} &= \bar{\alpha}_A \bar{\alpha}_{B'} \exp \{-i(\alpha_P \bar{\alpha}_{P'} \cdot X^{PP'})\}. \end{aligned}$$

The ϕ_{AB} thus derived corresponds to the ϕ_{AB} for a real circularly-polarised wave, which is in fact left-handed. Thus the spinor representation of complex states splits the states so that the positive energy part of the spinor with unprimed indices has negative helicity, while the positive energy part of the spinor with primed indices has positive helicity.

1.3. Momentum and angular momentum

In special relativistic dynamics any finite system possesses a total momentum p^a (a 4-vector) and a total angular momentum M^{ab} (skew tensor) dependent on the origin O. If $O \rightarrow \tilde{O}$, then $p^a \rightarrow \tilde{p}^a = p^a$ and $M^{ab} \rightarrow \tilde{M}^{ab} = M^{ab} - 2X^{[a} p^{b]}$ where X^a is the displacement $\vec{O\tilde{O}}$.

For an empty region surrounding a source, this also holds globally if and only if a certain ten integrals vanish [14].

We may define the spin vector

$$S_a := -\frac{1}{2} \eta_{abcd} P^b M^{cd}. \quad (1.29)$$

Then

$$\tilde{S}_a = S_a.$$

i) Assume $P_c P^c > 0$. Then the relativistic centre of mass of the system is defined to move on the worldline which is the locus of origins \tilde{O} such that

$$\tilde{P}_a \tilde{M}^{ab} = 0. \quad (1.30)$$

Then, as regards its total momentum and angular momentum the system behaves as a single particle moving along this worldline with momentum \tilde{P}_a and intrinsic spin \tilde{M}^{ab} . Equation (1.30) may be solved for X^a as

$$X^a = M^a_b P^b / (P_c P^c) + \lambda P^a$$

and this gives a unique timelike worldline. The intrinsic spin is

$$\tilde{M}^{ab} = \eta^{abcd} S_c P_d / (P_e P_e).$$

ii) However we wish to consider zero rest mass (i.e. $P_c P^c = 0$) to be the more fundamental case. Then (1.30) has no solution unless

$$M_{ab} P^b = -P_a (P^b X_b).$$

Thus there is no solution unless

$$\begin{aligned} M^{ab} P_b \propto P^a &\Leftrightarrow P^{[a} M^{b]c} P_c = 0 \Leftrightarrow P^{[a} M^{bc]} P_c = 0 \\ &\Leftrightarrow P_{[c} S_{d]} = 0 \\ &\Leftrightarrow S_d = s P_d \end{aligned}$$

for some constant s , the helicity, whose modulus $|s|$ is the spin⁹. (This equation may also be deduced from other points of view about particles.) $X^b P_b = k$, k being a constant, is a null hyperplane K , so it appears that the "centre of mass line" has become a 3-dimensional region. We can say a little more by considering two cases separately:

a) Spin $|s| = 0$. Then $M^{ab} = 2A^{[a} P^{b]}$ where A^a is some vector, and the centre of mass line can be defined as

$$X^a = A^a + \lambda P^a,$$

the angular momentum about a point on this line being

$$\tilde{M}^{ab} = 0.$$

Thus we may pick a specific generator of the hypersurface as the centre of mass line, and, as in the case where $P_a P^a > 0$ and $|s| = 0$, the system is completely characterised by this line.

⁹We shall choose units such that $\hbar = 1$. Then for quantum systems $|s|$ takes half integer values.

b) Spin $|s| \neq 0$. In this case all points on the null hyperplane $P^a X_a = k$ turn out to be on an equal footing. That is, one can find Poincaré transformations under which any two given points are dynamically equivalent. In this sense *the particle is not localised*. However, if we take two points $a, b \in K$, the necessary Poincaré transformation demonstrating the equivalence of a and b is not simply a translation, but a translation plus a specific null rotation (Trautman in [35]).

The null vector P^a corresponds to a spinor $\pi_{A'}$,

$$P_a = \bar{\pi}_A \pi_{A'} \tag{1.32}$$

uniquely up to phase; $\pi_{A'} \rightarrow e^{i\theta} \pi_{A'}$, preserves P_a . $M^{ab}(=M^{[ab]})$ is represented by a symmetric spinor,

$$M^{ab} = \mu^{AB} \epsilon^{A'B'} + \epsilon^{AB} \bar{\mu}^{A'B'}$$

The equation $S^a = sP^a$ takes the form

$$S_{DD'} = -i\bar{\pi}_D \pi^{A'} \bar{\mu}_{A'D'} + i\bar{\pi}^A \mu_{AD} \pi_{D'} = s \bar{\pi}_D \pi_{D'} \tag{1.33}$$

If we transvect this with $\bar{\pi}^D$ we find $\mu_{AB} \bar{\pi}^A \bar{\pi}^B = 0$ which implies that

$$\mu_{AB} = i\omega_{(A} \bar{\pi}_{B)}$$

for some ω^A . Since any symmetric 2-index spinor is the symmetrised outer product of two spinors⁶, the only new information concerning μ_{AB} is that one of the factors is $\bar{\pi}_A$. Thus

$$M^{AA'BB'} = i\bar{\pi}^{(A} \omega^{B)} \epsilon^{A'B'} - i\pi^{(A'} \bar{\omega}^{B')} \epsilon^{AB} \tag{1.34}$$

We can now characterise the pair (P_a, M^{ab}) by the two spinors $(\omega^A, \pi_{A'})$ (but not uniquely, for the same pair is represented by $(e^{i\theta} \omega^A, e^{i\theta} \pi_{A'})$). This pair is a (representation of a) *twistor*¹⁰ Z^α . We do not choose to *define* the twistor Z^α as the pair of spinors $(\omega^A, \pi_{A'})$ since under change of origin (and under conformal rescaling) the ω^A and $\pi_{A'}$ become transformed, whereas the twistor Z^α is supposed to remain unaffected. Thus we must think of $(\omega^A, \pi_{A'})$ simply as a *representation* of the twistor Z^α . In fact twistors have two stages of representation. The first, in terms of the above pair of spinors, is specified by a given origin and choice of conformal scale, i.e. of one of the conformally related flat metrics. (The spinor indices are here just abstract labels¹.) The second is in terms of the coordinates of these spinors with respect to some spinor frame. Such coordinates will be indicated by the presence of Hebrew indices.

If Z^α is represented by $(\omega^A, \pi_{A'})$ then we can take twistor components

$$Z^{\aleph} = (\omega^0, \omega^1, \pi_0, \pi_1) \tag{1.35}$$

We define a conjugate twistor \bar{Z}_α to have components

$$\bar{Z}_\aleph = (\bar{\pi}_0, \bar{\pi}_1, \bar{\omega}^{0'}, \bar{\omega}^{1'}) \tag{1.36}$$

Dropping the spinor frame, we have the representations $Z^\alpha \leftrightarrow (\omega^A, \pi_{A'})$, $\bar{Z}_\alpha \leftrightarrow (\bar{\pi}_A, \bar{\omega}^{A'})$ and so

$$Z^\alpha \bar{Z}_\alpha = \omega^A \bar{\pi}_A + \pi_{A'} \bar{\omega}^{A'} = 2s \tag{1.37}$$

⁶Note that as twistors will have well-defined translational transformations, they differ from Dirac spinors, see [5]. Quantities that are essentially twistors have been described by other authors [16].

using (1.33). Note that the Hermitian form used on the twistor Z^α in (1.37) has signature $(++--)$ and that positive ($s > 0$) and negative ($s < 0$) helicities are thus both possible.

When $s = 0$ the twistor is said to be null and represents a null worldline. When $s \neq 0$, the twistor represents a particle with intrinsic spin and there is a sense in which this means that the worldline is displaced into the complex. The particle ceases to be localised in M . The remaining sections will develop the twistor concept.

2. Twistors in flat space

2.1. Basic ideas; conformal invariance

In section 1.3 the concept of a twistor Z^α and its complex conjugate \bar{Z}_α were introduced, Z^α being represented by a pair of spinors $(\omega^A, \pi_{A'})$ which define the momentum and angular momentum of a massless particle by (1.32) and (1.34), \bar{Z}_α being correspondingly represented by $(\bar{\pi}_A, \bar{\omega}^A)$. The helicity of the particle is one-half the Hermitian norm $Z^\alpha \bar{Z}_\alpha$ of the twistor. Twistors also have a linear structure (i.e. $\lambda Z^\alpha \leftrightarrow (\lambda \omega^A, \lambda \pi_{A'})$; $Z^\alpha + Z^\alpha \leftrightarrow (\omega^A + \omega^A, \pi_{A'} + \pi_{A'})$) so we may expect the group of transformations which preserves these structures to have some significance. Since the signature of the form $Z^\alpha \bar{Z}_\alpha$ is $(++--)$, this group is $U(2,2)$. But if we wish to retain the geometrical significance of the phase of a twistor in terms of a polarisation plane (i.e. the flag plane direction of $\pi_{A'}$) then we are led to consider the group $SU(2,2)$ this being actually 4-1 homomorphic with the restricted conformal group. It turns out that twistors form a 4-1 representation space for the identity-connected component of the conformal group. The algebra of twistors is discussed in detail in [5]. Twistor space is 8-real-dimensional (4 complex dimensions). We may regard these dimensions as arising as follows; there is a five-dimensional set of null geodesics in M (consider the generators of the light cones with vertices at the points of any fixed spacelike surface) and on each geodesic one may give the momentum scaling (one parameter); the seventh dimension is the polarisation (phase of $\pi_{A'}$) and the eighth the intrinsic spin. The non-vanishing of intrinsic spin ($s \neq 0$) implies we do not have a uniquely-defined null geodesic, nor can we easily extend our interpretation to curved space-times (see section 3). Twistors are a sort of "square root" of the momentum and angular momentum in the same sense in which spinors are a "square root" of vectors.

In section 1.3 we said that a twistor was represented by a pair of spinors in a way dependent on choice of origin and conformal scale. We now need to know how the representation alters on change of origin and/or scale. Let us first consider the effect of a change of origin on the spinors which represent the twistor. When $O \rightarrow \tilde{O}$, we have $P_a \rightarrow \tilde{P}_a = P_a$; $M^{ab} \rightarrow \tilde{M}^{ab} = M^{ab} - 2X^{[ap]b}$. If we further insist that the phase of $\pi_{A'}$ be unaltered on translation owing to its interpretation as a polarisation plane (flag plane) we find

$$\tilde{\pi}_{A'} = \pi_{A'}; \tilde{\omega}^A = \omega^A - i X^{AA'} \pi_{A'}, \tag{2.1}$$

i.e. given g_{ab} , $\tilde{\omega}^A$ is a function of position (\tilde{O}) and may be regarded as a spinor field. (Actually it corresponds, in the case of null twistors, to a field of null directions of straight lines intercepting the worldline, see [5].) By (2.1)

$$\nabla^{A'(A} \tilde{\omega}^{B)} = 0. \tag{2.2}$$

In fact the form (2.1) follows from (2.2). For (2.2) implies $\nabla_{A'}^A \tilde{\omega}^B$ is skew in AB ; so also is $\nabla_C^C \nabla_{A'}^A \tilde{\omega}^B$ and hence (since in flat space we may commute the derivative operators) this latter is skew in CB and therefore in CAB . Thus it is zero, so $\nabla_{A'}^A \tilde{\omega}^B$ is constant. If this constant is written $-ie^{AB} \pi_{A'}$ (being skew in AB), the general solution of (2.2) is seen to be (2.1).
 Since

$$\pi_{A'} = \frac{1}{2} i \nabla_{AA'} \tilde{\omega}^A \tag{2.3}$$

the field $\tilde{\omega}^A$ completely defines the twistor. Moreover, by (1.19) etc., we see that (2.2) is invariant under a conformal rescaling with $\tilde{\omega}^B = \tilde{\omega}^B$. Thus a spinor field $\tilde{\omega}^B$ satisfying (2.2) can be used as a conformally invariant definition of a twistor, which therefore tells us how a spinor representation of a twistor behaves under change of origin or scale. It should be noted that change of origin preserves $\pi_{A'}$, but alters ω^A , while conformal rescaling preserves ω^A but alters $\pi_{A'}$, the point being that, as viewed from the origin, conformal rescalings make infinity appear to be in a different place; the spinor $\pi_{A'}$ is associated with the vertex I_o of the null cone at infinity in the same way that ω_A is associated with the origin O .

If we define (dropping the \sim from here onward)

$$W^a = \omega^A \bar{\omega}^{A'}$$

then

$$\nabla^{(a} W^{b)} = \frac{1}{4} g^{ab} (\nabla_c W^c) \tag{2.4}$$

so that W^b is a conformal Killing vector. However,

$$M^{ab} = \nabla [a W^{b]}$$

is not conformally invariant. Thus the angular momentum is not a conformal invariant, although W^a (or ω^A) is. In fact, from (1.20)

$$\hat{M}^{ab} = \Omega^{-2} (M^{ab} + 2\Upsilon [a W^{b}]).$$

This also follows from

$$\hat{\omega}^A = \omega^A; \quad \hat{\pi}_{A'} = \pi_{A'} + \Upsilon_{AA'} \omega^A \tag{2.5}$$

and (1.34) which further implies that

$$s = \frac{1}{2} (\omega^A \bar{\pi}_{A'} + \pi_{A'} \bar{\omega}^A) \tag{2.6}$$

is conformally invariant. It is the conformal invariance of (2.2) and (2.6), together with linearity, which shows that twistors form a representation space (locally) for the conformal group.

Now let us consider the equation

$$\nabla_{P'}^{(M} \alpha^{AB\dots L)} = 0 \tag{2.7}$$

which may be regarded as the many-index spinor equation generalising $\nabla_{P'}^{(M} \omega^A) = 0$. The equation is conformally invariant if its solution obeys

$$\hat{\alpha}^{AB\dots L} = \alpha^{AB\dots L}.$$

If we now form

$$\Psi_{AB...D} = \alpha^{E...L} \phi_{AB...DE...L} \tag{2.8}$$

where ϕ is a solution to (1.25) we find that $\Psi_{...}$ satisfies (1.25) for a lower spin. In fact (2.7) has $\binom{3+n}{3}$ linearly independent solutions if α has n indices, as shown explicitly in [5], p. 362. Each solution in turn, for a given n , may be substituted in (2.8).

For example, in the case of linearised gravitation $\phi_{...}$ we can form

$$\Psi_{AB} = \alpha^{CD} \phi_{ABCD}$$

which is a Maxwell field. We may ask what charge integrals this gives. There are 10 independent solutions for α^{CD} , so we will obtain 10 conserved (complex) quantities. These are in fact the energy, momentum and angular momentum [14]. (These quantities would be complex for a general solution of (1.25) but we get only 10 real quantities for a ϕ_{ABCD} derivable from a potential.) If the integrations are performed at infinity, these quantities give the Bondi-Sachs definition of mass [17], as applied to a general (shearing) retarded null hypersurface in Minkowski space, for linearised theory, so that it becomes clear that the "correction terms" which distinguish this mass measure from the Newman-Unti mass [18] are really necessary – even in linearised theory.

The equation

$$\nabla_{B'}^{(B} \omega^{A)} = 0 \tag{2.9}$$

which defines a twistor has 4 linearly independent solutions in M' . There is a difficulty at infinity because to form M we stick the past and future light cones together and the (one-superfix) twistors differ at those points by a factor i , essentially because the representation of the conformal group in twistor space is via a four-fold covering (cf. [19]). (For a many-index twistor, one must allow a factor i for each superfix and one factor $-i$ for each suffix.) We could remove this difficulty by taking a fourfold covering of M but instead we simply adopt the rule of multiplying by i every time we complete a circuit passing through infinity. The problem is an illustration of the fact that twistors are like spinors in not being local geometric objects (for odd-indexed spinors are multiplied by -1 when they are rotated through 2π).

2.2. Twistor space and Minkowski geometry

A twistor with $2s = Z^\alpha \bar{Z}_\alpha = 0$ represents a null real straight line (i.e. the worldline of some particle of zero spin). If $s \neq 0$ there is no such real line, but there is in a certain sense a "complex line". Clearly when $s = 0$, Z^α and λZ^α ($\lambda \neq 0$) represent the same line so that the most directly geometrically interpretable twistor space is the space N of equivalence classes $\{\lambda Z^\alpha\}$ when $s = 0$, $Z^\alpha \neq 0$, i.e.

$$N = \{ \{ \lambda Z^\alpha : \lambda \neq 0, \lambda \in \mathbb{C} \} : Z^\alpha \bar{Z}_\alpha = 0, Z^\alpha \neq 0 \} , \tag{2.10}$$

which represents the set of null lines in M . We shall therefore consider the space C of equivalence classes of twistors, defined like N but without the requirement $s = 0$ (fig. 3). This is complex projective three-space¹¹ $\mathbb{CP}(3)$ which has three complex or six real dimensions. It is not just the com-

¹¹For matters pertaining to projective geometry see [20].

plexification of
may be repre
transformation:

Let us now c
intersection of
 $\gamma^a \leftrightarrow (\xi^A, \eta_A)$.

$$\omega^A =$$

Formally this is

$$p^{AA'}$$

but of course th
lines do meet (i

$$\bar{\eta}_A \omega^A$$

i.e. Z

Thus the necess

$$Y^\alpha \bar{Y}_\alpha$$

These are also s
in which case th

Note that the spin
[5].

We shall use boldf
tures in both C and

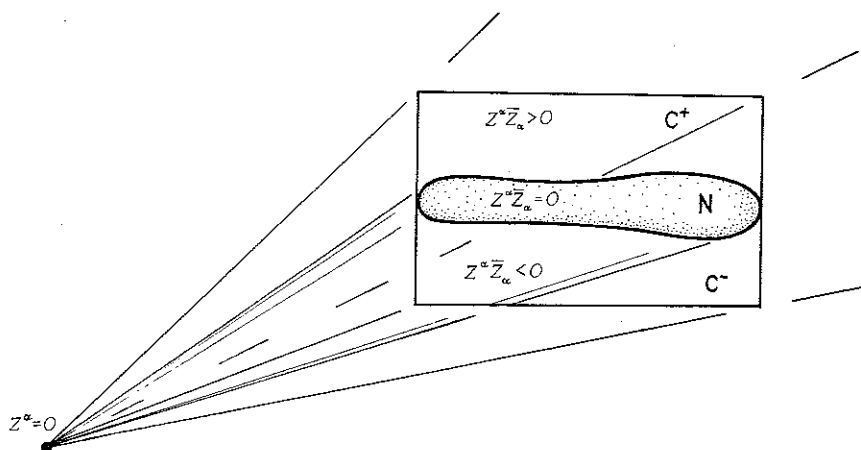

Fig. 3. Projection of twistor space into C.

plexification of N, which would have ten real dimensions. In fact even the complex points of C may be represented as real structures¹² (Robinson congruences) in M [5, 21, 22]. The conformal transformations of M correspond to projective point transformations¹¹ of C preserving N.

Let us now consider what a point in M corresponds to in C. We may define a point in M by the intersection of null lines. Suppose two lines are described by twistors $Z^\alpha \leftrightarrow (\omega^A, \pi_{A'})$, $Y^\alpha \leftrightarrow (\xi^A, \eta_{A'})$. Then the lines meet if there is a common solution to

$$\omega^A = ip^{AA'} \pi_{A'}; \quad \xi^A = ip^{AA'} \eta_{A'}$$

Formally this is

$$p^{AA'} = \frac{-i}{\pi_{B'} \eta^{B'}} (\omega^A \eta^{A'} - \xi^A \pi^{A'}) \tag{2.11}$$

but of course the corresponding point need not be real, i.e. $p^{AA'}$ need not be "Hermitian". If the lines do meet (i.e. p^a real) then

$$\bar{\eta}_A \omega^A = i \bar{\eta}_A p^{AA'} \pi_{A'} = i \bar{\eta}_A \bar{p}^{AA'} \pi_{A'} \pi_{A'} = -\bar{\xi}^{A'} \pi_{A'}$$

$$\text{i.e. } Z^\alpha \bar{Y}_\alpha = 0.$$

Thus the necessary conditions for the two twistors to represent real intersecting lines are

$$Y^\alpha \bar{Y}_\alpha = 0; \quad Z^\alpha \bar{Z}_\alpha = 0; \quad Z^\alpha \bar{Y}_\alpha = 0. \tag{2.12}$$

These are also sufficient [5] if we interpret the condition appropriately when Y and Z are parallel¹³, in which case they meet at infinity, i.e. lie in a null hyperplane [5]. This can be shown, assuming

¹²Note that the spinor field representation (section 2.1) represents twistors up to a factor $\pm i$ or ± 1 , i.e. it includes proportionality [5].

¹³We shall use boldface kernel letters, e.g. Z, to represent the twistor up to proportionality, and the corresponding geometric structures in both C and M pictures, reserving indexed letters, e.g. Z^α , for the actual twistors, etc..

Y and Z to be non-parallel so that π^A and η^A are not proportional (and then taking a limit for the parallel case), by testing the Hermiticity of (2.11) by taking components with respect to π^A and η^A . The three conditions thus derived for Hermiticity are simply (2.12).

If (2.12) holds, then it is also satisfied if Y^α (or Z^α) is replaced by

$$X^\alpha = \mu Z^\alpha + \lambda Y^\alpha$$

for any complex numbers μ, λ . Thus the line X meets each of Y and Z and so belongs to the null cone through the point P with position vector p^a . This null cone can be used to represent P. Thus P is represented in N by the linear set $\mu X^\alpha + \lambda Y^\alpha$, i.e. by the (complex) line P joining points Z and Y (which has 2 real dimensions and topology S^2).

We may therefore represent this point P by the 2-index twistor

$$\begin{aligned}
 P_{\alpha\beta} = Z^\alpha Y^\beta - Y^\alpha Z^\beta &\leftrightarrow \begin{pmatrix} \omega^A \xi^B - \xi^A \omega^B & \omega^A \eta_{B'} - \xi^A \pi_{B'} \\ \pi_{A'} \xi^B - \eta_{A'} \omega^B & \pi_{A'} \eta_{B'} - \eta_{A'} \pi_{B'} \end{pmatrix} \\
 &= \pi_{D'} \eta^{D'} \begin{pmatrix} -\frac{1}{2} \epsilon^{AB} p_{CC'} p^{CC'} & i p^A{}_{B'} \\ -i p_{A'}{}^B & \epsilon_{A'B'} \end{pmatrix} \tag{2.13}
 \end{aligned}$$

where $p^a = p^{AA'}$ is the position vector of the point P. Thus the points of M correspond (up to proportionality) to simple skew 2-index twistors, i.e. twistors obeying

$$P^{\alpha\beta} = p^{[\alpha\beta]}; \quad p^{[\alpha\beta} p^{\gamma\delta]} = 0 \text{ (i.e. } p^{[\alpha\beta} p^{\gamma\delta]} = 0).$$

We may define the dual twistor $P_{\alpha\beta}$ (which gives the geometrically dual description of the same line¹¹) by

$$P_{\alpha\beta} = \frac{1}{2} P^{\rho\sigma} \epsilon_{\alpha\beta\rho\sigma} \tag{2.14}$$

One may verify that p^a is real $\Leftrightarrow P_{\alpha\beta} = \bar{P}_{\alpha\beta}$ where $\bar{P}_{\alpha\beta}$ is the twistor complex conjugate of $P^{\alpha\beta}$. More generally, if p^a is complex, then its complex conjugate \bar{p}^a corresponds to $\bar{P}^{\alpha\beta}$ in the same way that p^a corresponds to $P^{\alpha\beta}$. In fact the imaginary part of p^a is spacelike, timelike or null respectively according as P intersects N in a one real-dimensional set (a curve: topology S^1), in a point, or not at all. If null or timelike, the imaginary part of p^a is future pointing or past-pointing according as P lies in $C^- \cup N$ or $C^+ \cup N$.

Now we recall that we are working in compactified Minkowski space (fig. 1). Suppose P is in fact I, the vertex of the null cone at infinity. Null lines at infinity have $\pi_{A'} = 0 = \eta_{A'}$, and so the point I corresponds to the twistor

$$I^{\alpha\beta} \leftrightarrow \begin{pmatrix} \epsilon^{AB} & 0 \\ 0 & 0 \end{pmatrix}.$$

This we shall call the 'infinity twistor'. Its dual is

$$I_{\alpha\beta} \leftrightarrow \begin{pmatrix} 0 & 0 \\ 0 & \epsilon_{A'B'} \end{pmatrix}.$$

We can normalise skew twistors by

$$P^{\alpha\beta} I_{\alpha\beta} =$$

This fails only if $\pi_{A'}$
Suppose now the

$$P^{\alpha\beta} Q_{\alpha\beta} =$$

(or for non-normali

$$4P^{\alpha\beta} Q_{\alpha\beta}/$$

This is clearly a Poi
leaves $I_{\alpha\beta}$ invariant
of four points, nam

$$\Phi = (P^{\alpha\beta} \zeta$$

which defines a sor

To sum up, a gen
to a point in CM, th
in N corresponds to
Klein representation
quadratic fourfold in
CM has eight real di

2.3. Solutions of th

The question we
that the general zer
(complex analytic)
to make the corresp
poles of f will be ph
contour integration
The solutions of
where $r = 0, 1, \dots, n; \sigma$

$$\phi_r = \phi_{AB\dots}$$

Now o_A and ι_B defini
 $\leftrightarrow (\iota_B, -i p^{BB'} \iota_B).$

$$(2.15)$$

$$\Phi_r(U_\alpha, V_t$$

There is no essential reas
the space of twistors; th
it turns out that spinor f
represented by functions c
handed particles (see sec

$$P^{\alpha\beta}I_{\alpha\beta} = 2 \quad (\text{i.e. } \pi_A \eta^{A'} = 1). \tag{2.16}$$

This fails only if π_A and $\eta_{A'}$ are proportional, i.e. only if P is at infinity.

Suppose now that $P^{\alpha\beta}I_{\alpha\beta} = Q^{\alpha\beta}I_{\alpha\beta} = 2$. Then by direct calculation we obtain

$$P^{\alpha\beta}Q_{\alpha\beta} = -(p^a - q^a)(p_a - q_a) =: -(PQ)^2 \tag{2.17}$$

(or for non-normalised twistors

$$4P^{\alpha\beta}Q_{\alpha\beta}/(I_{\rho\sigma}P^{\rho\sigma})(Q^{\delta\gamma}I_{\delta\gamma}) = -(p^a - q^a)(p_a - q_a).$$

This is clearly a Poincaré invariant quantity. In fact the subgroup of the conformal group which leaves $I_{\alpha\beta}$ invariant is just the Poincaré group. We can form a conformal invariant from the twistors of four points, namely

$$\Phi = (P^{\alpha\beta}Q_{\alpha\beta})(R^{\rho\sigma}S_{\rho\sigma})/(P^{\lambda\mu}S_{\lambda\mu})(R^{\tau\nu}Q_{\tau\nu}) = (PQ)^2(RS)^2/(PS)^2(RQ)^2$$

which defines a sort of "cross-ratio" for any four points in M .

To sum up, a general (complex projective) line in the (projective) twistor space C corresponds to a point in CM , the complexification of M ; a line in N corresponds to a real point in M ; a point in N corresponds to a null line in M . Starting from the space C we can reconstruct CM as the Klein representation¹¹ of lines in the complex three-dimensional projective space C , giving CM as a quadric fourfold in five-dimensional projective space. (In this case all dimensions are complex, so CM has eight real dimensions, cf. [23].)

2.3. Solutions of the zero-rest-mass field equations

The question we now discuss is how fields in M are represented in twistor space. We shall find that the general zero-rest-mass free fields can be remarkably concisely represented by holomorphic (complex analytic) functions $g(Z^\alpha)$ and $f(W_\alpha)$ on the twistor space and its dual¹⁴, C^* . But in order to make the correspondence we must take suitable contour integrals. Thus only the residues at the poles of f will be physically meaningful; consequently the subsequent formalism will be based on contour integration in C .

The solutions of the equations (1.25) can be represented by a set of quantities $\phi_r(P; o^A, t^B)$ where $r = 0, 1, \dots, n$; o^A, t^B are a pair of basis spinors at the point P , and

$$\phi_r = \phi_{AB\dots L} \frac{t^A \dots t^D}{r} \frac{o^E \dots o^L}{n-r}.$$

Now o_A and t_B define null twistors through P , namely¹⁴ U_α, V_β say, i.e. $U_\alpha \leftrightarrow (o_A, -ip^{AA'}o_A)$, $V_\beta \leftrightarrow (t_B, -ip^{BB'}t_B)$. Thus we have the quantities

$$\Phi_r(U_\alpha, V_\beta) = \phi_r(P; o^A, t^B), \quad r = 0, \dots, n.$$

¹⁴There is no essential reason why we should not represent our geometric objects using the space of dual twistors, rather than the space of twistors; there is a quite free choice between these spaces. However, with the choices of convention we have made, it turns out that spinor fields with unprimed indices, whose positive energy parts represent left-handed particles, must be represented by functions on the dual twistor space, while spinors with primed indices, whose positive energy parts represent right-handed particles (see section 1.2) will be represented by functions on the twistor space.

If U_α and V_β are restricted to be null twistors with real intersection, Φ_r represent a zero-rest-mass field in M . Such a field may be regarded as defined on some *three*-parameter initial set (Cauchy hypersurface) and thence extended over the rest of space by the field equations. In twistor terms it would be economical if we could describe the field on M by some field on the (complex) 3-space C , or C^* . So far it appears that we must define the field on *pairs* of points U, V in C^* .

Let us take the point P and define a standard tensor and spinor reference frame (cf. (1.6)) such that

$$u = p^{00'} = \frac{p^0 + p^1}{\sqrt{2}}; \quad \zeta = p^{01'} = \frac{p^2 + ip^3}{\sqrt{2}}$$

$$\tilde{\zeta} = p^{10'} = \frac{p^2 - ip^3}{\sqrt{2}}; \quad v = p^{11'} = \frac{p^0 - p^1}{\sqrt{2}}$$

$\bar{\zeta} = \tilde{\zeta}$, $u = \bar{u}$, $v = \bar{v}$ if and only if p^a is real. The field equations (1.25) become

$$\partial\phi_r/\partial\tilde{\zeta} = \partial\phi_{r+1}/\partial u; \quad \partial\phi_r/\partial v = \partial\phi_{r+1}/\partial\zeta; \quad r = 0, \dots, n-1. \tag{2.18}$$

These equations are automatically satisfied if

$$\phi_r = \frac{1}{2\pi i} \oint_K \lambda^r F(\lambda, u + \lambda\tilde{\zeta}, \zeta + \lambda v) d\lambda \tag{2.19}$$

where F is a holomorphic (i.e. analytic or regular in the complex sense) function of three complex variables, the contour K being taken to surround the poles of F in a suitable way. The resulting fields will always be analytic in the real sense with respect to $u, v, \zeta, \tilde{\zeta}$, but we may represent non-analytic fields as limits of analytic ones.

A real null vector at $p^a = (u, v, \zeta, \tilde{\zeta})$ has direction given by $du : dv : d\zeta : d\tilde{\zeta}$ where

$$du + \lambda d\tilde{\zeta} = 0 = d\zeta + \lambda dv$$

for some complex λ (possibly infinite). For the Minkowski metric is $2(du dv - d\zeta d\tilde{\zeta})$ so that $du dv = d\zeta d\tilde{\zeta}$ for a null direction. Thus $du : dv : d\zeta : d\tilde{\zeta} = \lambda\bar{\lambda} : 1 : -\lambda : -\bar{\lambda}$. The corresponding (null) twistor is $U_\alpha + \lambda V_\alpha = W_\alpha \leftrightarrow (\bar{\pi}_A, \bar{\omega}^{A'})$ where

$$\bar{\pi}_{01} \pi_{01'} \propto \begin{pmatrix} dv & -d\tilde{\zeta} \\ -d\zeta & du \end{pmatrix}$$

and $\lambda = \bar{\pi}_1/\bar{\pi}_0 = W_1/W_0$. Thence, as $\bar{\omega}^{A'} = -ip^{AA'} \pi_{A'}$,

$$(W_2, W_3) = (\bar{\omega}^{0'}, \bar{\omega}^{1'}) = -i(\bar{\pi}_0, \bar{\pi}_1) \begin{pmatrix} u & \zeta \\ \tilde{\zeta} & v \end{pmatrix} = -i W_0(u + \lambda\tilde{\zeta}, \zeta + \lambda v).$$

Thus $(W_0, W_1, W_2, W_3) = W_0(1, \lambda, -i(u + \lambda\tilde{\zeta}), -i(\zeta + \lambda v))$. If we therefore set

$$f(W_\alpha) = (W_0)^{-n-2} F(W_1/W_0, iW_2/W_0, iW_3/W_0)$$

then $f(W_\alpha)$ is homogeneous of degree $-n-2$ in W_α . (We can now check that this has the correct

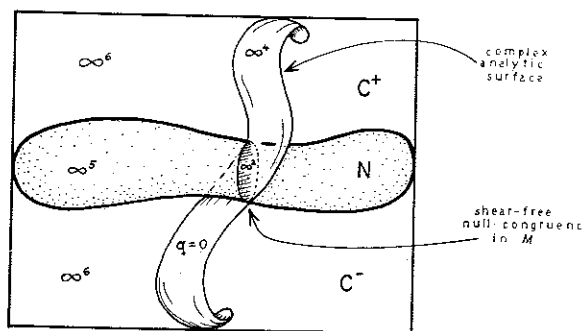

Fig. 4. The Kerr theorem.

transformation properties under rotation¹⁵ for spin $\frac{1}{2}n$.) The final formula is

$$(2.18) \quad \Phi_r(U_\alpha, V_\beta) = \frac{1}{2\pi i} \oint_K \lambda^r f(U_\alpha + \lambda V_\alpha) d\lambda. \quad (2.20)$$

We may now generalise by taking any U_α, V_β (no longer necessarily null) thus defining complex fields on complex points $U_{[\alpha} V_{\beta]}$. It seems (although there is as yet no completely satisfactory theorem) that the set of such fields is extremely general. For a particular field it is clear that f is not unique since all the contour integrals remain the same under $f \rightarrow f + h$ where h is regular inside the contour. We may regard this as a sort of gauge invariance. This non-uniqueness of f would clearly lead to difficulties for any proposed explicit formula giving f in terms of $\phi_{A...L}$.

It is however easy to construct special types of solution for f . For example $\phi_{A...L}$ is called null if

$$\phi_{AB...L} = \alpha_A \alpha_B \dots \alpha_L$$

and such a field arises when the contour surrounds only a single simple pole [24]. (Note that a general symmetric spinor may be written as a symmetrised product of one-spinors⁶ [2, 9].) More generally, the algebraically special fields

$$\phi_{AB...L} = \alpha_{(A} \alpha_B \beta_C \dots \lambda_{L)}$$

appear as integrals round contours surrounding a pole of order $\leq (n - 1)$. E.g. to obtain type {2,2} (i.e. Petrov type D) linearized Weyl tensor fields we may require that f has two triple poles and that the contour separates one of them from the other. (Since here f has homogeneity degree -6, it follows that such an f is in fact the inverse cube of a quadratic form.)

If ϕ is algebraically special (e.g. null) there is associated with it a shearfree null congruence [22].

$$f(W_\alpha) = p(W_\alpha)/q(W_\alpha)$$

then $q(W_\alpha) = 0$ is a four (real) dimensional surface in a six dimensional space (C), and intersects

⁶ See [21] for more details.

the 5-dimensional surface N in a 3-dimensional set of points (fig. 4). This represents a 3-parameter null congruence in M . By a theorem of R.P. Kerr (unpublished, see [21]), this congruence must be shearfree. The theorem is that a congruence of null lines is shearfree if and only if it is representable in C as the intersection of N with a complex analytic surface S in C (or as a limiting case of such an intersection). It was partly this theorem that motivated the study of holomorphic functions in twistor space.

If we suppose $q = 0$ is a plane (i.e. $q(W_\alpha) = A^\alpha W_\alpha$) then we obtain by the above method a "linear" system of null lines in M (a Robinson congruence [5]), which we may consider to be a geometrical picture of the (complex) twistor A^α (which previously had no intuitively obvious picture associated with it). These "Robinson" congruences are largely what led to the name twistor, for they are shearfree, and twist with a handedness dependent on the sign of $A^\alpha \bar{A}_\alpha$.

If we consider a sourcefree spin $\frac{1}{2}n$ massless field in M (compactified Minkowski space), which has the correct peeling-off behaviour towards infinity [4], then the field will not match at infinity [19] unless we take a fourfold covering for odd n (twofold for $n \equiv 0 \pmod{4}$). (This is reflected in the behaviour of the integrals introduced above since the homogeneity degree of $f(Z)$ is $-n-2$ and twistors are 4-valued, see section 2.1.) Rather than work with awkward covering spaces, however, we shall make the convention that a source-free field with the correct peeling-off properties is to be regarded as continuous across infinity if it has the right "Grgin discontinuity" at infinity (i.e. a general free wave of spin $\frac{1}{2}n$ should jump by a factor of i^{n+2} [19, 21]).

Consider then fields with the correct peeling-off and Grgin behaviour (which momentum eigenstates, for example, do not have). These may be (uniquely) split into positive and negative energy fields (cf. [25]). A process equivalent to Grgin's harmonic analysis technique [19] applied to the positive energy fields is the following. Instead of $\bar{Z}_0 = \bar{Z}^2$ etc., let us take twistor coordinates so that we get the more natural-looking $\bar{Z}_S = (\bar{Z}^0, \bar{Z}^1, -\bar{Z}^2, -\bar{Z}^3)$, the Hermitian form $Z^\alpha \bar{Z}_\alpha$, of signature $(++--)$, being now diagonalised. The orthonormal basis $\{E_\alpha\}$ then has two vectors of positive and two of negative length. These points give us four planes (fig. 5) and the simplest possible function of positive frequency has as its singular region just the planes shaded in fig. 5 (cf. [21]). A general function for spin $\frac{1}{2}n$ fields of positive frequency is

$$f(\bar{Z}_\alpha) = \sum_{a_0 a_1 a_2 a_3} \frac{(\bar{Z}_0)^{a_0} (\bar{Z}_1)^{a_1}}{(\bar{Z}_2)^{a_2+1} (\bar{Z}_3)^{a_3+1}} f_{a_0 a_1 a_2 a_3} \tag{2.21}$$

where $f_{a_0 a_1 a_2 a_3}$ is a constant and a_0, a_1, a_2, a_3 are non negative integers satisfying $a_0 + a_1 + n = a_2 + a_3$. If S is the set of singularities of this function then assuming suitable convergence $S \cap C^*$ is disconnected in two pieces, and so will yield a positive frequency field [21]. The individual terms in (2.21) will in fact form an orthogonal basis according to the scalar product of section 3.3.

For a further discussion of the material of this section see [21, 24].

2.4. Quantisation

We start out by considering how to connect the spin s of relativistic dynamics, which appeared in the classical twistor picture of angular momentum discussed above (section 1.3) with the spin s of the zero-rest-mass fields just considered.

The momentum of a particle with zero-spin was described by $\pi_A (\bar{\pi}_A \pi_{A'} = p_a)$ while the position of the centre of mass is then determined by $\omega^A = iX^{AA'} \pi_{A'}$. As

$Z^\alpha \leftrightarrow$
we find that
 $iZ^\alpha d\bar{Z}$

$X^{AA'}$ is real. T
 idZ^α
and the right-ha
Hamiltonian eq
we should regard
theory we would
(etc.).

In the operat
 $P_a = i$
 $P_a X^b$
units being chos
 $Z^\alpha = \partial$

and
 $Z^\alpha \bar{Z}_\beta$
where these oper
essentially given
are similarly desc

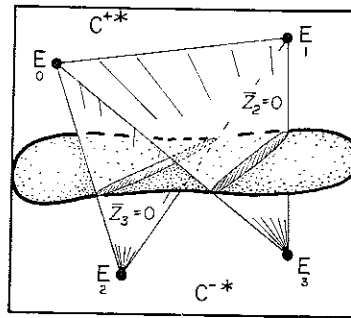

Fig. 5.

$$Z^\alpha \leftrightarrow (\omega^A, \pi_{A'}) \quad \bar{Z}_\alpha \leftrightarrow (\bar{\pi}_{A'}, \bar{\omega}^{A'})$$

we find that

$$\begin{aligned} iZ^\alpha d\bar{Z}_\alpha &\leftrightarrow i\omega^A d\bar{\pi}_{A'} + i\pi_{A'} d\bar{\omega}^{A'} \\ &= -X^{AA'} \pi_{A'} d\bar{\pi}_A + \pi_{A'} d(X^{AA'} \bar{\pi}_A) \\ &= -X^{AA'} \pi_{A'} d\bar{\pi}_A + \pi_{A'} (dX^{AA'}) \bar{\pi}_A + \pi_{A'} X^{AA'} d\bar{\pi}_A \\ &= \pi_{A'} \bar{\pi}_A dX^{AA'} = P_a dX^a \end{aligned} \tag{2.22}$$

if $X^{AA'}$ is real. Thus, taking the exterior derivative,

$$idZ^\alpha \wedge d\bar{Z}_\alpha = dP_a \wedge dX^a \tag{2.23}$$

and the right-hand side is just the two-form preserved under canonical transformations, i.e. by Hamiltonian equations. (For a fuller account of this correspondence see [26].) This suggests that we should regard $-iZ^\alpha, \bar{Z}_\alpha$ as canonically conjugate variables. Thus in the passage to a quantum theory we would expect $-iZ^\alpha, \bar{Z}_\alpha$ to become canonically conjugate operators (with $\bar{Z}_\alpha \propto \partial/\partial Z^\alpha$, etc.).

In the operator form

$$\begin{aligned} P_a &= i \partial/\partial x^a \quad (\text{and } X^a = -i \partial/\partial P_a) \\ P_a X^b - X^b P_a &= i \delta_a^b, \end{aligned} \tag{2.24}$$

units being chosen so that $\hbar = 1$. Thus we shall want

$$Z^\alpha = \partial/\partial \bar{Z}_\alpha \quad (\bar{Z}_\alpha = -\partial/\partial Z^\alpha)$$

and

$$Z^\alpha \bar{Z}_\beta - \bar{Z}_\beta Z^\alpha = \delta_\beta^\alpha, \tag{2.25}$$

where these operators are taken to act on functions $f(\bar{Z}_\alpha)$. Now in the method of section 2.3, ϕ is essentially given by $f(\bar{Z}_\alpha)$, and it is clear from taking complex conjugates that solutions of (1.28) are similarly described by a function $g(Z^\alpha)$. Now

$$\begin{aligned} Z^\alpha f(\bar{Z}) &= \frac{\partial}{\partial \bar{Z}_\alpha} f(\bar{Z}); & \bar{Z}_\alpha f(\bar{Z}) &= \bar{Z}_\alpha f(\bar{Z}) \\ Z^\alpha g(Z) &= Z^\alpha g(Z); & \bar{Z}_\alpha g(Z) &= -\frac{\partial}{\partial Z^\alpha} g(Z). \end{aligned} \quad (2.26)$$

Previously we had $Z^\alpha \bar{Z}_\alpha = 2s$, where $S^\alpha = sP^\alpha$, s being the spin parallel to the direction of motion. So consider the operator S defined by

$$4S := Z^\alpha \bar{Z}_\alpha + \bar{Z}_\alpha Z^\alpha = 2(\bar{Z}_\alpha Z^\alpha + 2) = 2(Z^\alpha \bar{Z}_\alpha - 2). \quad (2.27)$$

Then

$$Sg(Z^\alpha) = \frac{1}{2}((n+2) - 2)g(Z^\alpha) = sg(Z^\alpha)$$

for g is homogeneous of degree $(-n-2)$ and $2s = n$ whereas $Z^\alpha \partial g(Z)/\partial Z^\alpha$ gives $kg(Z^\alpha)$ where k is the homogeneity degree. (One may, incidentally, say that the fact that $\delta_\alpha^\alpha = 4$ in twistor space, i.e. its 4-dimensionality, is related to the need for the degree $(-n-2)$ in the definition of f .) We also find $Sf(\bar{Z}_\alpha) = sf(\bar{Z}_\alpha)$ if $n = -2s$, so that the twistor fields corresponding to spinors with primed indices are of opposite helicity, as we expect. The fact that the spin is half-integral is a consequence of the one-valuedness of f .

We may inquire what is the effect of Z^α, \bar{Z}_α when acting on the fields $\phi \dots$. Consider

$$f(W_\alpha) \rightarrow (Q^\alpha W_\alpha) f(W_\alpha), \quad (2.28)$$

which is the result of $Q^\alpha \bar{Z}_\alpha$. If $Q^\alpha \leftrightarrow (Q^A, Q_{A'})$, eq. (2.28) corresponds to

$$\phi_{AB\dots L} \rightarrow \tilde{Q}^A \phi_{AB\dots L} = \psi_{B\dots L}, \quad (2.29)$$

where $\tilde{Q}^A = Q^A - iX^{AA'} Q_{A'}$, and $\psi_{B\dots L}$ satisfies the zero-rest-mass field equations for spin $(n-1)$. Similarly, if $R_\alpha \leftrightarrow (R_A, R^A)$, the operator $R_\alpha Z^\alpha$ acts so that

$$f(W_\alpha) \rightarrow R_\beta \frac{\partial}{\partial W_\beta} f(W_\alpha); \quad (2.30)$$

$\phi_{AB\dots L} \rightarrow \frac{1}{2}i(n+1)\phi_{(AB\dots L} \nabla_{M)M'} \tilde{R}^{M'} + i\tilde{R}^{M'} \nabla_{M'M} \phi_{AB\dots L} = \chi_{AB\dots M}$, where $\chi_{AB\dots M}$ is a solution of the zero rest mass field equations for spin $(n+1)$. Thus \bar{Z}_α raises, and Z^α lowers, the helicity by one-half.

3. Twistors in curved space

There are three approaches to the problem of generalising the twistor formalism to curved space-time. These lead to three somewhat different twistor concepts, which will be referred to as global twistors, local twistors and asymptotic twistors.

Global twistors are the most logical generalisation of ordinary flat-space twistors to a curved space-time. However, they suffer from two serious shortcomings, namely that they have only a rather weak structure (merely symplectic, rather than linear and/or complex analytic) and that only the null twistors can be precisely defined in geometrical terms, the existence of the non-null twistors being simply postulated.

Local twistors, on the other hand, have a well-defined existence (whether null or non-null) and a linear and complex analytic structure. But they are necessarily defined relative to points in the space-time so they cannot in themselves be regarded as a satisfactory generalisation of the flat-space twistors, adequate to form a basis for a formalism in which space-time points are to be regarded as derived objects. Local twistors give rise to a conformally invariant calculus on a space-time manifold. This may have some utility as such; but the main value of the local twistor concept lies in its use in the definition of asymptotic twistors.

The asymptotic twistor concept is one which applies only to a space-time which is asymptotically flat. However this is the situation appropriate to an S-matrix theory of gravitation and consequently has great relevance for the twistor quantisation programme. The space of asymptotic twistors has a complex analytic structure with a (non-linear) Hermitian scalar product defined – giving rise to a (pseudo-) Kählerian (and hence also a symplectic) structure. Asymptotic twistors, which were developed after the lectures on which these notes are based were given, are discussed in section 5. A brief description of local twistor theory will be given here and global twistor theory and its relation to gravitational scattering will be discussed.

3.1. Local twistors

In this approach we define a twistor space at each point of space-time¹⁶. This twistor space may be thought of as the direct sum of a spin-space and a conjugate spin space. However the exact way in which the twistor space splits up as a direct sum depends on the choice of conformal scaling. More explicitly, a local twistor Z^α at a point p can be represented, with respect to the metric g_{ab} , by a pair of spinors $(\omega^A, \pi_{A'})$ at p . Under a conformal rescaling (cf. section 2.1) we will have (cf. (2.5), (1.19a))

$$(2.29) \quad \hat{g}_{ab} = \Omega^2 g_{ab}; \quad \hat{\omega}^A = \omega^A; \quad \hat{\pi}_{A'} = \pi_{A'} + i\Upsilon_{AA'}\omega^A. \quad (3.1)$$

This is consistent with the behaviour already encountered in flat space-time since in that case we have

$$(2.30) \quad \hat{\nabla}_{AA'}\hat{\omega}^B = \hat{\nabla}_{AA'}\omega^B = \nabla_{AA'}\omega^B + \epsilon_A{}^B\Upsilon_{CA'}\omega^C \quad (3.2)$$

whence

$$i\hat{\epsilon}_A{}^B\hat{\pi}_{A'} = i\epsilon_A{}^B\pi_{A'} - \Upsilon_{CA'}\omega^C\epsilon_A{}^B \quad (3.3)$$

follows from

$$\nabla_{AA'}\omega^B = -i\epsilon_A{}^B\pi_{A'}. \quad (3.4)$$

However this last equation can only be maintained in conformally-flat space-time. Nevertheless it supplies motivation for (3.1) which will be retained for local twistors in curved space-time.

The calculation of covariant derivatives of local twistors is most easily accomplished by introducing projection and injection operators from the twistor space to the two spin-spaces which represent it. Thus we define¹⁷

$$e_\alpha^A, e_{\alpha A'}, e_A^\alpha, e^{\alpha A'}$$

¹⁶I.e. for one-superspace twistors we form a fibre bundle over space-time with fibre the (8-dimensional) twistor space.
¹⁷Here we follow unpublished work of K. Dighton, which is partially based on a suggestion of A. Qadir.

such that $Z^\alpha e_\alpha^A = \omega^A$, $Z^\alpha e_{\alpha A} = \pi_A$, etc. and

$$\begin{aligned} e_\alpha^A e_B^\alpha &= \epsilon_B^A, & e_\alpha^A e^{\alpha A'} &= 0, & e_{\alpha A} e^{\alpha B'} &= \epsilon_A^{B'}, & e_{\alpha A} e_\alpha^A &= 0, \\ e_\alpha^A e_A^\beta + e_{\alpha A} e^{\beta A'} &= \delta_{\alpha'}^\beta, & \bar{e}_\alpha^A &= e^{\alpha A'}, & \bar{e}_A^\alpha &= e_{\alpha A}. \end{aligned} \tag{3.5}$$

Under conformal rescaling we will have $Z^\alpha \rightarrow \hat{Z}^\alpha = Z^\alpha$ while $\omega_A, \pi_{A'}$ transform by (3.1). Thus we see that

$$\begin{aligned} \hat{e}_\alpha^A &= e_\alpha^A; & \hat{e}_{\alpha A'} &= e_{\alpha A'} + i\Upsilon_{AA'} e_\alpha^A, \\ \hat{e}^{\alpha A'} &= e^{\alpha A'}; & \hat{e}_A^\alpha &= e_A^\alpha - i\Upsilon_{AA'} e^{\alpha A'}. \end{aligned} \tag{3.6}$$

We now have to decide how the projection operators vary as we pass from one point to another. We find we require (cf. (1.21))

$$\begin{aligned} \nabla_{RS'} e^{\alpha A'} &= i\epsilon_{S'}^A e_R^\alpha, & \nabla_{RS'} e_\alpha^A &= -i\epsilon_R^A e_{\alpha S'}, \\ \nabla_{RS'} e_A^\alpha &= iP_{RAS'} e^{\alpha A'}, & \nabla_{RS'} e_{\alpha A'} &= -iP_{RAS'} e_A^\alpha. \end{aligned} \tag{3.7}$$

We have $\omega^A = e_\alpha^A Z^\alpha$, $\pi_{A'} = e_{\alpha A'} Z^\alpha$ so that

$$\begin{aligned} \nabla_\rho^\sigma Z^\alpha &= e^{\sigma S'} e_\rho^R \nabla_{RS'} (e_A^\alpha \omega^A + e^{\alpha A'} \pi_{A'}) \\ &= e_\rho^R e^{\sigma S'} \{ e_A^\alpha (\nabla_{RS'} \omega^A + i\epsilon_R^A \pi_{S'}) + e^{\alpha A'} (\nabla_{RS'} \pi_{A'} + iP_{RBS'} \omega^B) \}. \end{aligned} \tag{3.8}$$

These forms (3.7), (3.8) are required in order to give a conformally invariant twistor derivative as can be checked using (3.1) and (3.6), and because in flat space, constant local twistors (i.e. those annihilated by $\nabla_{RS'}$) will now correspond to our former global flat-space twistors¹⁸. When referred to a basis (3.8) has, in all, 64 components, 48 of them being zero. ∇_ρ^σ satisfies the usual requirements of a derivative (linearity and the Leibniz rule) and it commutes with complex conjugation and contraction.

We may now consider

$$\nabla_\rho^\sigma \nabla_\tau^\mu - \nabla_\tau^\mu \nabla_\rho^\sigma = [\nabla_\rho^\sigma, \nabla_\tau^\mu].$$

Acting on a scalar function ϕ , this gives us

$$[\nabla_\lambda^\mu, \nabla_\rho^\sigma] \phi = i(\delta_\lambda^\sigma \nabla_\rho^\mu - \delta_\rho^\mu \nabla_\lambda^\sigma) \phi = T_{\lambda\rho\beta}^{\mu\sigma\alpha} \nabla_\alpha^\beta \phi \tag{3.9}$$

where

$$T_{\lambda\rho\beta}^{\mu\sigma\alpha} = i(\delta_\lambda^\sigma \delta_\rho^\alpha \delta_\beta^\mu - \delta_\rho^\mu \delta_\beta^\sigma \delta_\lambda^\alpha).$$

Then

$$K_{\lambda\rho\beta}^{\mu\sigma\alpha} Z^\beta = i \{ [\nabla_\lambda^\mu, \nabla_\rho^\sigma] - T_{\lambda\rho\beta}^{\mu\sigma\gamma} \nabla_\gamma^\beta \} Z^\alpha \tag{3.10}$$

¹⁸Eq. (3.8) shows that a constant local twistor in flat space has constant $\pi_{A'}$, and ω^A satisfying (3.4), i.e. we retrieve the spinor field representation of a twistor, and so the correspondence just referred to is that the local twistor at a point P has the same representation as the global twistor has when referred to P as origin.

where

$$K_{\lambda\rho\beta}^{\mu\sigma\alpha} = e_\lambda^L e^{\mu A} + \epsilon$$

These define given by (3.1 Note that, $Q_{\alpha\beta}^\gamma$ for exact of $Q_A^{B'G}$, Q^A formally invariant conformally derivatives ∇' applied. (K. I tensors in this

3.2. Global tw

Consider a pole direction identify such a structure invariant (cf. (nor can we use) sional manifold consider N to ing, formally, described as the simple terms.

The space of dimensional symplectic structure. This structure presenting geometry N represent. S the fact that ing, is such a plectic structure general curved congruence will be shearing at the shear-free of the C-pictu

¹⁹One might, for a geodesic (twistor) PO. This does not

where

$$K_{\lambda\rho\beta}^{\mu\sigma\alpha} = e_{\lambda}^L e^{\mu M'} e_{\rho}^R e^{\sigma S'} [e_{\beta}^B \{e_A^{\alpha} i \epsilon_{M'S'} \Psi^A{}_{BLR} - e^{\alpha A'} (\epsilon_{RL} \nabla_B^{B'} \bar{\Psi}_{B'M'S'A'} - \epsilon_{M'S'} \nabla_A^A \Psi_{ARLB})\} + e_{\beta B'} e^{\alpha A'} i \epsilon_{RL} \bar{\Psi}_{A'M'S'}]. \tag{3.11}$$

(3.1). Thus

These define a torsion twistor $T_{\lambda\rho\beta}^{\mu\sigma\alpha}$ and a curvature twistor $K_{\lambda\rho\beta}^{\mu\sigma\alpha}$. The spinor components of $K_{\lambda\rho\beta}^{\mu\sigma\alpha}$ given by (3.11) involve Ψ_{ABCD} and $\nabla_P^A \Psi_{ABCD}$.

(3.6)

to another.

(3.7)

Note that, by the conformal transformation rules for twistors (section 2.1), any local twistor $Q_{\alpha\beta}^{\gamma}$ for example, defines a conformally invariant spinor $Q^{A'B'G}$. If this spinor vanishes, then each of $Q_A^{B'G}$, $Q^{A'B'}_G$, $Q^{A'B'}_G$ is conformally invariant, etc. etc.. Thus any non-vanishing local twistor defines at least one non-vanishing conformally invariant spinor. In particular we can apply this to $K_{\kappa\mu\nu}^{\alpha\beta\gamma}$ (to obtain $\epsilon_{B'G'} \Psi^A{}_{LMN}$) or to derivatives $\nabla_{\rho}^{\sigma} K_{\lambda\mu\nu}^{\alpha\beta\gamma}$, $\nabla_{\xi}^{\tau} \nabla_{\sigma}^{\rho} K_{\lambda\mu\nu}^{\alpha\beta\gamma}$ etc., or to such derivatives to which symmetry operations have been applied. (K. Dighton has shown how to obtain the Bach tensor and other conformally invariant tensors in this way.)

3.2. Global twistors

(3.8)

derivative as
ors (i.e. those
When referred
sual require-
conjugation

Consider a null geodesic Z with a parallelly propagated spinor π_A , defined along it whose flag-pole direction is tangent to Z . By analogy with the situation in flat space we may reasonably identify such a structure as a null (global) twistor in curved space. This description is conformally invariant (cf. (1.19a)). (We do not give a spinor representation of a twistor relative to each point¹⁹, nor can we use our former description of a non-null twistor.) Null twistors form a seven-dimensional manifold N (5 dimensions for the set of null geodesics, 2 for the set of spinors π_A). We shall consider N to be embedded in an abstract 8-dimensional manifold C , the points of $C-N$ representing, formally, the non-null twistors. This is done because the structure of N is most easily described as that induced from the embedding of N in C , the structure of C being describable in simple terms. No precise geometrical definition of the elements of $C-N$ will (can?) be given.

(3.9)

(3.10)

The space C will have a symplectic structure. Symplectic structures are only possible in even-dimensional spaces, and symplectic manifolds of the same dimension are locally congruent. The symplectic structure of C induces on N a structure which has geometric significance in the space-time. This structure on N expresses relations between neighbouring points of N , these relations representing geometrical connections between the null geodesics (and π_A spinors) that the points of N represent. Such geometrical connections must refer to properties of null geodesics. For example, the fact that a congruence of null geodesics has vanishing *rotation*, i.e. is (null) hypersurface forming, is such a property and it turns out that this property is simply describable in terms of the symplectic structure of C . The *shear* of a null congruence, on the other hand, is something which, in a general curved space-time, can be defined only in relation to points on the null geodesics. A null congruence which is shear-free at one point will, in the presence of conformal curvature, generally be shearing at other points. Recall that the Kerr theorem established a close connection between the shear-free condition for null congruences in flat space-time and the complex analytic structure of the C -picture. The fact that the concept "shear-free" cannot, in general curved space-times, be

retrieve the spinor
at P has the same re

¹⁹One might, for example, try to define (ω^A, π_A) at a point O by taking the intersection P of the null cone at O with the null geodesic (twistor) and parallelly propagating the π -spinor along the null geodesic PO or else using local twistor transport along PO . This does not appear to agree with the type of structure we shall require the twistor space to have.

applied to null geodesics in their entirety, strongly indicates that C cannot generally be given a geometrically meaningful complex analytic structure.

Let us investigate the structure of C for a particular type of curved space-time M , namely one which possesses two regions M_1 and M_2 of flat space-time separated by a curved region of M , through which null geodesics can pass from M_1 to M_2 . This will enable us to examine the structure of C in relation to the structure we have previously obtained for flat space-time. By involving two flat metrics we shall be able to isolate the structure of C as that which is common to the structures induced by each of M_1 and M_2 . Now in each of M_1 and M_2 we can represent twistors in terms of pairs of spinors and hence in terms of four complex components Z^0, Z^1, Z^2, Z^3 (subject to $Z^{\mathbb{S}}\bar{Z}_{\mathbb{S}}=0$). The expressions $Z^{\mathbb{S}}d\bar{Z}_{\mathbb{S}}$ and $dZ^{\mathbb{S}} \wedge d\bar{Z}_{\mathbb{S}}$ define forms²⁰ on N which as we shall show are the same whether the coordinates $Z^{\mathbb{S}}$ are defined in M_1 or in M_2 . Each of the forms $\phi = iZ^{\mathbb{S}}d\bar{Z}_{\mathbb{S}}$ and $\omega = d\phi = idZ^{\mathbb{S}} \wedge d\bar{Z}_{\mathbb{S}}$ defines structure of geometrical significance in M . It turns out, in fact, that ϕ measures time separation between neighbouring geodesics, while ω measures rotation, see also [26].

Let us consider two examples, both of flat spaces M_1, M_2 joined across a null hypersurface K , the (degenerate) metric of K being the same whether induced by M_1 or M_2 . The curvature resides entirely within K , having the form of a δ -function on K .

A. Take two flat spaces

$$\begin{aligned} M_1: \quad ds^2 &= 2(du \, dv - d\zeta \, d\bar{\zeta}), & v &\leq 0 \\ M_2: \quad ds^2 &= 2(du^* \, dv^* - d\zeta^* \, d\bar{\zeta}^*), & v &\geq 0 \end{aligned} \tag{3.12}$$

joined on the null hyperplane $v = 0 = v^*$ where $\zeta^* = \zeta; u^* = u - q(\zeta\bar{\zeta})$. This has a δ -function in curvature on the join (rather as the surface of a cylinder of finite extent has, at the join of the end and the side – both of which are flat)²¹. The Ricci curvature is (essentially) $\delta(v)\partial^2 q/\partial\zeta\partial\bar{\zeta}$, while the conformal curvature is (essentially) $\delta(v)\partial^2 q/\partial\zeta^2, \delta(v)\partial^2 q/\partial\bar{\zeta}^2$. Einstein's empty space field equations yield

$$\partial^2 q/\partial\zeta\partial\bar{\zeta} = 0, \quad \text{whence } q = r(\zeta) + \bar{r}(\bar{\zeta}), \tag{3.13}$$

r being a holomorphic (i.e. complex analytic) function.

B. Similarly join flat spaces

$$\begin{aligned} M_1: \quad ds^2 &= du \, dv - u^2 d\zeta \, d\bar{\zeta}, & v &\leq 0 \\ M_2: \quad ds^2 &= du^* \, dv^* - u^{*2} d\zeta^* \, d\bar{\zeta}^*, & v &\geq 0 \end{aligned} \tag{3.14}$$

along $v = 0$ (a null cone) with $\zeta^* = f(\zeta)$ (f being a holomorphic function); $u^* = u/|f'(\zeta)|$. It turns out that this automatically satisfies Einstein's vacuum field equations. (For a fuller discussion of this case see [29].)

In these examples the passage of a null geodesic through $v = 0$ is determined by the condition that it is orthogonal to the same vectors within $v = 0$ on each side of the join. (The behaviour can also be found by considering an appropriate limit of C^∞ spaces.) This tells us how a twistor is af-

²⁰For an introduction to Cartan forms see e.g. [27].

²¹This space is in fact a limiting case of the plane-fronted waves [28], see [21], while (3.14) is a limiting case of the Robinson-Trautman waves [31].

ected by an impulsive wave. In both cases the null geodesic is scattered in a way that can be formulated in Hamiltonian terms.

Let us see this explicitly in terms of example A. A twistor Z^α representing a null line, with coordinates as in section 2.3, has

$$\begin{aligned} Z^0:Z^1:Z^2:Z^3 &= -iud\zeta + i\bar{\zeta}du: -i\bar{\zeta}d\bar{\zeta} + ivdu: -d\zeta: du \\ &= -iudv + i\zeta d\bar{\zeta}: -i\bar{\zeta}dv + iud\bar{\zeta}: -dv: d\bar{\zeta}. \end{aligned}$$

Thus it satisfies

$$-Z^3d\zeta = Z^2du, \quad -Z^3dv = Z^2d\bar{\zeta}, \tag{3.15a}$$

$$Z^1 = i\bar{\zeta}Z^2, \quad Z^0 = i\zeta Z^3 + iuZ^2 \tag{3.15b}$$

(since we are considering a point on K where $v = 0$). The starred version of (3.15b) also holds. Thus

$$Z^{*1} = i\bar{\zeta}Z^{*2}, \quad Z^{*0} = i\zeta Z^{*3} + i(u - q)Z^{*2}. \tag{3.16}$$

In order to write the remainder of the starred version of (3.15) in terms of $du, dv, d\zeta$ we need to use the fact that Z^* and Z are orthogonal to the same vectors in K at the point $Z \cap K$. Denoting a direction at $Z \cap K$ by $\delta u: \delta v: \delta \zeta$ in the u, v, ζ system we have $\delta v = 0$ if the direction lies in K . For the direction to be orthogonal to that of Z we require

$$\delta u dv + 0 du = \delta \zeta d\bar{\zeta} + \delta \bar{\zeta} d\zeta \tag{3.17}$$

whence, from (3.15)

$$\delta u = -\delta \zeta Z^3/Z^2 - \delta \bar{\zeta} \bar{Z}^3/\bar{Z}^2. \tag{3.18}$$

The starred version of this gives, from (3.12),

$$\delta u - \frac{\partial q}{\partial \zeta} \delta \zeta - \frac{\partial q}{\partial \bar{\zeta}} \delta \bar{\zeta} = -\delta \zeta Z^{*3}/Z^{*2} - \delta \bar{\zeta} \bar{Z}^{*3}/\bar{Z}^{*2}. \tag{3.19}$$

Equations (3.18) and (3.19) must represent identical conditions on $\delta u: \delta \zeta: \delta \bar{\zeta}$ since they must give the same 2-plane element. Hence

$$Z^3:Z^2 = Z^{*3} - Z^{*2} \frac{\partial q}{\partial \zeta}: Z^{*2}. \tag{3.20}$$

Equations (3.15), (3.16) and (3.20) define the ratios of the $Z^{*\alpha}$ components in terms of the ratios of the Z^α components, by elimination of ζ and u . With the most convenient choice of scale factor we can set

$$\begin{aligned} Z^{*3} &= Z^3 + Z^2 \partial q / \partial \zeta; & Z^{*2} &= Z^2 \\ Z^{*1} &= Z^1, & Z^{*0} &= Z^0 - iZ^2(q - \zeta \partial q / \partial \zeta) \end{aligned} \tag{3.21}$$

where $\zeta = iZ^1/\bar{Z}^2$. Setting

$$H(Z^\alpha, \bar{Z}_\alpha) \equiv |Z|^2 q \tag{3.22}$$

we can write (3.21) comprehensively as

$$Z^{*\alpha} = Z^\alpha - i \partial H / \partial Z_\alpha \tag{3.23}$$

The same formula, with H real and homogeneous of degree one separately in Z^α and in \bar{Z}_α , is also valid for case B, though H now depends on $f(\xi)$, rather than q . In the infinitesimal change case we find

$$\delta Z^\alpha = Z^{*\alpha} - Z^\alpha = -i \partial H / \partial \bar{Z}_\alpha; \quad \delta \bar{Z}_\alpha = i \partial H / \partial Z^\alpha \tag{3.24}$$

which are equations of the Hamiltonian type and so preserve the symplectic structure [21, 26]. In fact $Z^\alpha \bar{Z}_\alpha, \phi = i Z^\alpha d\bar{Z}_\alpha; Z^\alpha \partial / \partial Z^\alpha; i(\partial / \partial Z^\alpha) \otimes (\partial / \partial \bar{Z}_\alpha) - i(\partial / \partial \bar{Z}_\alpha) \otimes (\partial / \partial Z^\alpha); idZ^\alpha \wedge d\bar{Z}_\alpha = \omega$ are all preserved in the sense that $\delta(Z^\alpha \bar{Z}_\alpha) = 0; \delta(Z^\alpha d\bar{Z}_\alpha) = 0; \delta \circ Z^\alpha \partial / \partial Z^\alpha = Z^\alpha \partial / \partial Z^\alpha \circ \delta$ and so on. If we define

$$[\chi, \Psi] := -i \frac{\partial \chi}{\partial Z^\alpha} \frac{\partial \Psi}{\partial \bar{Z}_\alpha} - i \frac{\partial \chi}{\partial \bar{Z}_\alpha} \frac{\partial \Psi}{\partial Z^\alpha} \tag{3.25}$$

then

$$\delta \Psi = [\Psi, H] \tag{3.26}$$

$$-\delta(dZ^\alpha) = d \left(i \frac{\partial H}{\partial \bar{Z}_\alpha} \right) = i \frac{\partial^2 H}{\partial Z^\beta \partial \bar{Z}_\alpha} dZ^\beta + i \frac{\partial^2 H}{\partial \bar{Z}_\beta \partial Z^\alpha} d\bar{Z}_\beta \tag{3.27}$$

and from these one can check the invariances mentioned above.

If we consider any weak gravitational wave of any shape whatever, which separates two regions of flat space-time, then we are led to equations of exactly similar form to the above. This is because weak gravitational waves can be superposed linearly and can be broken down into a superposition of waves of the above types only. (Actually plane waves alone will suffice for this.) The corresponding H functions are likewise linearly composed of those above.

We must define what we mean by ϕ, ω on the N associated with a general curved space. In flat space we have seen that (2.22, 2.23)

$$\phi \equiv i Z^\alpha d\bar{Z}_\alpha = P_a dx^a \tag{3.28a}$$

$$\omega \equiv idZ^\alpha \wedge d\bar{Z}_\alpha = dP_a \wedge dx^a = \nabla_{[a} P_{b]} dx^a \wedge dx^b \tag{3.28b}$$

where for the right hand expressions of (3.28b) we take P_a to be the tangent vector field of a congruence of geodesics. In curved space we use these as definitions of ϕ, ω . This is possible because $P_a dx^a$ and $dP_a \wedge dx^a$, as forms applied to connecting vectors of neighbouring geodesics, are constant (the constancy in this sense of $dP_a \wedge dx^a$ being the well-known Lagrange identity, see [26, 27]) and since N (modulo the phase factors) has been identified with the space of null geodesics the forms ϕ, ω will be invariantly defined on N .²² The expressions (3.28) lead to the interpretations of ϕ and ω mentioned before as respectively, time-displacement and rotation of neighbouring null geodesics.

²²See footnote on the next page.

In bo
we may
where g
so we ob
The infi
conform
We ca
with mo
where e
the parti
of the gr
separated
particle c
to the pa
transform
out to be
 $H^* = f(Z^f$
equation:
position
We hav
Footnote
(i.e. manif
e.g. the co
Then on a
which W n
alence clas
situation c
In the ca
space S giv
be obtaine
 $Z^\alpha \rightarrow e^{i\theta} Z^\alpha$
obtain G a
case, or eq

(3.22) In both the examples A and B above we find, provided Einstein's vacuum equations hold, that we may write

(3.23)
$$H(Z^\alpha, \bar{Z}_\alpha) = H^+ + H^-; \quad H^+ = \bar{H}^-$$

$$H^+ = \bar{Z}_\alpha I^{\alpha\beta} \partial g / \partial Z^\beta$$
 where $g(Z^\alpha)$ is holomorphic and homogeneous of degree 2 in Z^α . Explicitly, for the case A, we have

(3.24)
$$H^+ = |Z^2|^2 \bar{r}(-iZ^1/Z^2) = \bar{Z}_\alpha I^{\alpha\beta} \partial(g(Z^\alpha)) / \partial Z^\beta,$$
 so we obtain (3.29) if

$$g(Z^\alpha) = i(Z^2)^2 \int_{x_0}^{-iZ^1/Z^2} \bar{r}(x) dx.$$

(3.25) The infinity twistor appears in (3.29) because gravitation is not conformally invariant: $I^{\alpha\beta}$ is the conformal-symmetry breaking term which tells us "where" infinity is.

We can similarly treat electromagnetic scattering, introducing charged zero-rest-mass particles, with momentum P^a . The acceleration of such a particle is

(3.26)
$$P^a \nabla_a P^b = e F^{ab} P_a$$
 where e is the charge and F^{ab} the Maxwell field. This gives well-defined equations of motion for the particle even though its rest-mass is zero. We can consider an idealised situation similar to that of the gravitational impulse waves considered above. Here we take two regions of field-free space separated by an electromagnetic plane or spherical wave of δ -function amplitude. A zero-rest-mass particle on either side of the wave may be described by a null twistor. The wave imparts an impulse to the particle and so defines a transformation of the twistor space from one side to the other. The transformation again turns out to be of Hamiltonian form, but now, in the infinitesimal case H turns out to be homogeneous of degree zero separately in Z^α and in \bar{Z}_α , where $H = H^+ + \bar{H}^-$ with $H^+ = f(Z^\beta)$ holomorphic and of degree zero in Z^α (assuming F^{ab} satisfies the free-space Maxwell equations). The treatment may likewise be extended to any infinitesimal scattering by linear superposition of such waves, and hence of the corresponding H functions.

(3.28a) We have encountered holomorphic functions in both the gravitational and electromagnetic cases.

(3.28b) Footnote from preceding page. The invariance of ω is closely related to some general theory concerning symplectic manifolds (i.e. manifolds with a two-form W of maximal rank such that $dW = 0$). Let T be any manifold, with a symplectic structure W , e.g. the cotangent bundle $T = T^*(M)$ of a manifold M , with $W = dP_a \wedge dx^a$, where P_a denotes a cotangent vector at x [26]. Then on any hypersurface S in T , W must be degenerate (S being odd-dimensional), and so at each point of S there is a vector which W maps to zero. If we factor out by equivalence along the integral curves of this vector field, the new manifold (of equivalence classes) again has a symplectic structure (with two less dimensions than that of T). This is assuming that the "normal" situation obtains, whereby the factoring procedure actually produces a smooth manifold (of two less dimensions than T). In the case of twistor space we may take $T^*(V_4)$, the cotangent bundle of space-time, and consider the seven-dimensional subspace S given by $P^a P_a = m^2 = 0$. The equivalence classes are the null geodesics, and the resulting six-dimensional space G can also be obtained by applying the same procedure to $T = C$, the hypersurface S now being N and the vector field on N generating $Z^\alpha \rightarrow e^{i\theta} Z^\alpha$. These transformations leave the null geodesic Z and its tangent vector $\bar{\pi}^A \pi^{A'} = P^a$ unaffected, so in either case we obtain G as the space of affinely parametrised null geodesics; its symplectic structure being induced by $dP_a \wedge dx^a$ in the first case, or equivalently, by $idZ^\alpha \wedge d\bar{Z}_\alpha$ in the second.

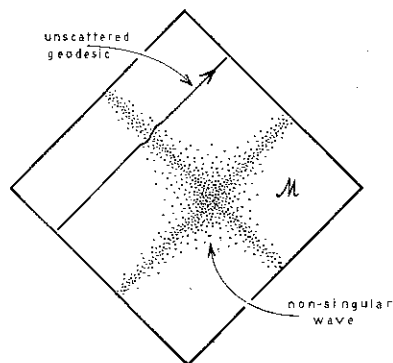

Fig. 6.

But in general these have poles, and if not, then H is a bilinear function of Z^α, \bar{Z}_α . For the fields of this latter simple type the null geodesics emerge ultimately unscattered although waves can come in and go out (fig. 6). However, in general cases where the wave possesses singularities, singularities in the function can exist and scattering occurs. For instance in example B above one can see from the fact that there is no non-singular non-constant harmonic function on a 2-sphere that the behaviour of $f(\xi)$ on the null cone joining the two flat spaces must be singular on at least one generator of the cone. This singularity could be cancelled by putting together an appropriate set of such cones but we would then be back to the situation of fig. 6 where there is no scattering.

3.3. Quantization

We wish to pass from the scattering of zero-rest-mass particles by a (weak) gravitational or electromagnetic wave to the scattering of zero rest mass fields. In general a zero rest mass field $\phi_{A'B'...L}$ is defined by a holomorphic function $f(Z^\alpha)$. We may now ask how to transform f in order to represent the scattering of the $\phi_{...}$ field. A somewhat formal answer is provided if we use the correspondence $\bar{Z}_\alpha \rightarrow -\partial/\partial Z^\alpha$ suggested by the fact that Z^α and \bar{Z}_α are canonically conjugate variables. Thus, we write

$$H(Z^\alpha, -\partial/\partial \bar{Z}^\alpha) \text{ for } H(Z^\alpha, \bar{Z}_\alpha),$$

and apply it to f . We are here regarding H as describing the effect of a fixed given gravitational field. Now with the H considered above for the scattering of massless particles by weak gravity we get

$$H^+ \rightarrow -\frac{\partial}{\partial Z^\alpha} \circ I^{\alpha\beta} \frac{\partial g}{\partial Z^\beta} = -\left(I^{\alpha\beta} \frac{\partial g}{\partial Z^\beta} \right) \frac{\partial}{\partial Z^\alpha} \tag{3.32}$$

the commutation being possible because $I^{\alpha\beta}$ is skew. Thus no factor ordering problem arises. Similarly we would have

$$H^- \rightarrow Z^\alpha I_{\alpha\beta} [\partial \bar{g} / \partial \bar{Z}_\beta] \bar{Z}_\beta \rightarrow -\partial / \partial Z^\beta$$

which is more awkward! However we aim to consider matrix elements $\langle g | H | f \rangle$ and therefore need not evaluate $H^- | f \rangle$ as such, for

R. F
and we ma
we mean b
we can be
duct used
From ϕ ,

At each
fine (with

where S is
dent of th
and that tl
Our nex
answers m
integration
contour in
degree (-
the integr
of the regi
For this w

We then fi
ogy class
To illus
represent
In a gravit

$$\langle g|H|f\rangle = \langle g|H^-|f\rangle + \langle g|H^+|f\rangle$$

and we may take H^- to act on $\langle g|$ writing $H^- \rightarrow (\delta/\partial\bar{Z}_\alpha)I_{\alpha\beta} \partial\bar{g}/\partial\bar{Z}_\beta$. So far we have not defined what we mean by $\langle g|f\rangle$ and our next task is therefore to set up a Hilbert space of functions f . In doing so we can be guided by the need for suitably nice formal formulae and agreement with the scalar product used by Fierz [30].

From $\phi_{A\dots L}$ we may construct a series of potentials $\overset{k \text{ indices}}{\phi_{EF\dots L}^{(k)A'B'\dots D'}}$ satisfying

$$\begin{cases} \nabla_{AA'} \overset{(1)}{\phi}_{B\dots L}^{A'} = \phi_{A\dots L} \\ \nabla_{DD'} \overset{(k)}{\phi}_{E\dots L}^{A'\dots D'} = \overset{(k-1)}{\phi}_{D\dots L}^{A'\dots C'} \\ \nabla^{EE'} \overset{(k)}{\phi}_{EF\dots L}^{A'B'\dots D'} = 0 \\ \nabla^m \nabla_m \overset{(n)}{\phi}_{A'B'\dots L} = 0. \end{cases} \tag{3.33}$$

At each step there is a gauge freedom in choice of $\overset{(k)}{\phi}$... cf. [4]. Following Fierz, we may now define (with suitable numerical constant k)

$$\langle \chi|\phi\rangle = k \int_S \overset{(n-1)}{\phi}_{L^{A'B'\dots K'}} \chi_{A'B'\dots L'} dS^{LL'} \tag{3.34}$$

where S is a spacelike surface. One must (and can) check that this is gauge independent, independent of the choice of surface, that one may interchange χ and ϕ yielding a Hermitian symmetry, and that the product is conformally invariant (cf. [36]).

Our next task is to express the scalar product in terms of $f(Z^\alpha), g(W_\alpha)$. Physically meaningful answers must be contour integrals since if f is replaced by f' where $f - f'$ is nonsingular inside the integration contour of eq. (2.20) the field is not changed. Let us investigate the form that such a contour integral must take. Suppose we have $\beta(Z^\alpha, X^\alpha, \dots, W_\alpha\dots)$ which is a function homogeneous of degree (-4) in each variable. To integrate one must define a differential form $\mathcal{D}ZX..W\dots$, so that the integral depends only on the homology class (relative to the space less regions of singularity) of the region of integration (i.e. we require that the resulting object is a genuine contour integral). For this we use

$$\left. \begin{aligned} \mathcal{D}Z &= \frac{1}{6} \epsilon_{\alpha\beta\gamma\delta} Z^\alpha dZ^\beta \wedge dZ^\gamma \wedge dZ^\delta \\ \mathcal{D}W &= \frac{1}{6} \epsilon^{\alpha\beta\gamma\delta} W_\alpha dW_\beta \wedge dW_\gamma \wedge dW_\delta \\ \mathcal{D}ZX..W\dots &= \mathcal{D}Z \wedge \mathcal{D}X \wedge \dots \wedge \mathcal{D}W \wedge \dots \end{aligned} \right\} \tag{3.35}$$

We then find that $d(\beta\mathcal{D}ZX..W\dots) = 0$ as required for $\oint \beta\mathcal{D}ZX..W\dots$ to be dependent on the homology class of the contour, and that the integral is a scalar, as we desire [21].

To illustrate the value of such contour integrals let us digress for a moment. If we take $\beta(Z^\alpha)$ to represent an electromagnetic field, then $\oint \beta(Z^\alpha)\mathcal{D}Z$ gives the charge integral for a source for the field. In a gravitational field the function $f(Z^\alpha)$ introduced before is of degree -6 , so we take

$$\oint Z^\alpha Z^\beta f(Z) \mathcal{D}Z$$

and find this is the twistor describing the energy momentum and angular momentum of a source for the field.

The same differential forms are now used for the scalar products in terms of f and g . We must insert additional factors so that $f(Z^\alpha)g(W_\alpha)$ has the correct homogeneity degree i.e. $(-4, -4)$. For $n = 0, 1$ this may be done by²³

$$\oint \underbrace{f(Z^\alpha)}_{\text{degree } -n-2} \underbrace{g(W_\alpha)}_{\text{degree } -n-2} (W_\beta Z^\beta)^{n-2} \mathcal{D}ZW \tag{3.36}$$

since there is then a 6-dimensional contour not homologous to zero in the 16-dimensional subspace of $C \otimes C^*$ where $f, g, (Z^\alpha W_\alpha)^{n-2}$ are non-singular (i.e. there is a contour surrounding the singularities). However for $n \geq 2$ this formula is no longer satisfactory since the $(Z^\alpha W_\alpha)^{n-2}$ singularity disappears. If we consider defining successive factors (as n increases) by integrating the previous ones, the factor for $n = 0$ will be $\log(W_\alpha Z^\alpha)$, which is not homogeneous. So we take

$$(x)_k = (-x)^{-k} \Gamma(k) \tag{3.37}$$

for non-integer k and formally define the values at integers by taking the obvious limit. The point is that for $k = -1, -2, \dots$ the singular behaviour of $\Gamma(k)$ compensates for the lack of a pole $(-x)^{-k}$. Thus in (3.36) for general n we write $(W_\alpha Z^\alpha)_{2-n}$ as defined by (3.37) in place of $(W_\alpha Z^\alpha)^{n-2}$. (In fact for $n = 0$ we are led to

$$\log \{ (W_\alpha Z^\alpha) / (W_{1\alpha} C_\beta D_{\gamma 1} Z^\alpha A^\beta B^\gamma) \} \tag{3.38}$$

and one does then find an answer which is independent of the auxiliary twistors $A^\gamma \dots D_\alpha$.) With these definitions it can be checked that the basis functions used in (2.21) are orthogonal. The functions $(W \cdot Z)_k$ do satisfy the formal property

$$\partial(W \cdot Z)_k / \partial Z^\alpha = W_\alpha (W \cdot Z)_{k+1} \tag{3.39}$$

which in fact is what is really used in actual calculations.

4. Evaluation of scattering amplitudes

4.1. Introduction

In this section we consider the evaluation of scattering amplitudes for basic processes involving zero rest-mass particles. It turns out that the twistor formalism suggests that certain types of contour integral be performed, each contour integral being associated with a graph of a particular type. In the case of electromagnetic scatterings the twistor calculations give agreement with the standard results for simple processes (e.g. Möller, Compton scattering) but a general theory is still lacking which relates the twistor approach explicitly with the normal Feynman rules. Also, the

²³The scalar product of two functions $f(Z^\alpha)$ and $\bar{g}(\bar{W}^\alpha)$ is defined to be zero unless they have the same spin and the same sign of frequency.

correct treati
not yet emer
tent unmotiv

The basic
morphic func
cess. These ir
pure momen
where pure n
momentum s

The wave |
the zero mas
from the twi
define the f'
f's, must itse
have seen an
product $\langle \alpha | \beta$
where the pa
gral is

$\oint a$

(cf. (3.37)).

In order to
be worthwhile
gravitational
scattering wa

H^+

where g is a h
tromagnetic s

H^+

where f is ho
compared wi
functions wh
(cf. section 2
as describing
degree) whic
We must exp
one. A formu
four in the el
Now consi

$g(Z$

correct treatment of rest-mass and of gravitational interactions within the twistor formalism has not yet emerged. Of necessity the treatment given here will be somewhat sketchy and to some extent unmotivated. A more complete treatment will have to await a more complete theory.

The basic idea here will be to use the twistor description of massless fields in terms of holomorphic functions (cf. section 2.3) in order to represent the in- and out-states of a scattering process. These in- and out-states should, strictly speaking, be wave packets, in this theory, rather than pure momentum states. This leads to certain difficulties in making comparisons with existing theory, where pure momentum states are almost invariably used. However, a formal method for treating momentum states within the twistor theory will also be given.

The wave packets defining the in- and out-states can be described by (normalized) solutions of the zero mass spin s equations: $\nabla^{AP'} \phi_{AB\dots L} = 0, \nabla^{PA'} \theta_{A'B'\dots L'} = 0$. Since these fields are obtained from the twistor holomorphic functions $f(Z)$ by means of contour integrations and they do not define the f 's uniquely, we must expect that any scattering amplitude which is a functional of the f 's, must itself be obtainable from the f 's by means of some form of contour integration. Now we have seen an example — albeit a trivial one — of a scattering amplitude already, namely the scalar product $\langle \alpha | \beta \rangle$. This expresses the amplitude that the out-state is $\alpha\dots$ given that the in-state is $\beta\dots$, where the particle enters and leaves without interacting. The corresponding twistor contour integral is

$$\oint a(W)b(Z) (W \cdot Z)_{2-n} \mathcal{D}WZ \tag{4.1}$$

(cf. (3.37)).

In order to motivate, to some extent, the generalizations of this to include interactions, it will be worthwhile briefly to examine the scatterings we considered in the last section by a classical gravitational or electromagnetic wave. Recall that the Hamiltonian $H = H^+ + H^-$ for a gravitational scattering was defined by

$$H^+ = \bar{H}^- = I^{\alpha\beta} \bar{Z}_\alpha \partial g / \partial Z^\beta \tag{4.2}$$

where g is a holomorphic function of Z^α which is homogeneous of degree +2, whereas for an electromagnetic scattering we had

$$H^+ = f \tag{4.3}$$

where f is holomorphic in Z^α and homogeneous of degree 0. These homogeneity degrees may be compared with -6 and -4 , respectively, which are the homogeneity degrees of those holomorphic functions which, upon contour integration, yield a linearized gravitational or electromagnetic field (cf. section 2.3). We may think of these latter holomorphic functions (the negative degree functions) as describing the fields in a "passive" capacity, whereas the holomorphic functions (non-negative degree) which appear in the Hamiltonian are "active" in that they effect scattering of other fields. We must expect that there should be some way of passing from a "passive" function to an "active" one. A formula which achieves this must have the effect of increasing the homogeneity degree by four in the electromagnetic case and by eight in the gravitational case.

Now consider the expressions (with numerical factors chosen for convenience)

$$g(Z^\alpha) = \frac{1}{(2\pi i)^3} \oint p(W_\alpha) (W_\beta Z^\beta)_{-2} \mathcal{D}W \tag{4.4a}$$

$$f(Z^\alpha) = \frac{1}{(2\pi i)^3} \oint q(W_\alpha)(W_\beta Z^\beta)_0 \mathcal{D}W \tag{4.4b}$$

where p and q have respective degrees of homogeneity -6 and -4 as is required for "passive" gravitational and electromagnetic functions. As a consequence the functions g and f have the required "active" degrees $+2$ and 0 , respectively. To some extent the expressions (4.4) must be regarded as merely formal, however. The reason for this is concerned with the nature of the singularity sets of p and q . Recall that in order to define a zero rest-mass field, we required not merely a holomorphic function, but also a division of its singularity sets in C^+ (or in C^-) into two disconnected regions, the contours being chosen so as to separate one region from the other. But this is not adequate for defining the contours for (4.4). Instead, one needs, for topological reasons, a division of the singularity sets of p and q into *three* disconnected regions²⁴. Thus more information is required, in order to evaluate g and f , than just that which is needed to evaluate the zero rest-mass fields from the functions p and q . Having made this observation, however, we may regard eqs. (4.4) as being valid in a certain sense. This may be verified explicitly by reference to particular functions p, q of the form $p(W_\alpha), q(W_\alpha) = 1/(W_\beta E^\beta)(W_\gamma F^\gamma)(W_\delta G^\delta)^n$ (with $G^\alpha I_{\alpha\beta} = 0$; $n = 4, 2$) which represent certain plane waves. The resulting $g(Z^\alpha), f(Z^\alpha) \propto (E^\alpha F^\beta K^\gamma Z^\delta \epsilon_{\alpha\beta\gamma\delta})^{n-1} / E^\lambda F^\mu G^\nu Z^\tau \epsilon_{\lambda\mu\nu\tau}$ (K^γ arbitrary) are essentially the correct "active" functions for this case. The general case may then be viewed as arising from linear combinations of such plane waves. But difficulties remain if we desire to make (4.4) rigorous.

Let us now attempt to use (4.4) in order to express the scattering of a zero rest-mass field by a gravitational field defined by p or by an electromagnetic field defined by q . According to section 3.3 we may expect to describe this scattering by means of a matrix $\langle \alpha | H^+ | \beta \rangle$ or $\langle \alpha | H^- | \beta \rangle$. Substituting (4.2) or (4.3) (with $\bar{Z}_\alpha \rightarrow -\partial/\partial Z^\alpha$ or $Z^\alpha \rightarrow \partial/\partial \bar{Z}_\alpha$) into (4.1) and using (4.4) we arrive at expressions of the form (again choosing numerical factors for convenience)

$$\begin{aligned} & \frac{1}{(2\pi i)^5} \oint a(W)(W_\gamma Z^\gamma)_{2-n} I^{\alpha\beta} \frac{\partial}{\partial Z^\alpha} b(Z) \frac{\partial}{\partial Z^\beta} \{(U_\delta Z^\delta)_{-2} p(U)\} \mathcal{D}WZU \\ & = - \frac{1}{(2\pi i)^5} \oint a(W) b(Z) p(U) (W \cdot Z)_{3-n} (U \cdot Z)_{-1} (I^{\alpha\beta} W_\alpha U_\beta) \mathcal{D}WZU \end{aligned}$$

and

$$\frac{1}{(2\pi i)^5} \oint a(W) b(Z) q(U) (W \cdot Z)_{2-n} (U \cdot Z)_0 \mathcal{D}WZU$$

respectively.

It will be useful to represent the singularity structure of the integrands of such contour integrals in a graphical way. The twistor variables which are to be integrated over will be represented by vertices, a black vertex denoting an upper index twistor (e.g. Z^α) and a white vertex a lower index twistor (e.g. W_α). A line joining two vertices denotes the singularity corresponding to the vanishing of the scalar product of the two twistors representing the two vertices. Thus lines are allowed joining vertices only if one is black and the other white. In addition, lines will be allowed which have a

²⁴In fact the functions considered in section 5.2 do not suffer from this fault.

vertex at or
b(Z), ..., v
two sets, so
stands for o
the form

b

Then we ma
A Z = 0, B
ends of the

In fig. 7 t
picted; the
our propose
with integer
or not verti
rated into t

(4.4b)

passive" have the re- must be re- the singu- l not merely two dis- ther. But this d reasons, a re informa- te the zero we may re- ference to par- $t_{\alpha\beta} = 0;$ $\epsilon_{\alpha\beta\gamma\delta})^{n-1}/$ ase. The gen- s. But diffi-

ass field by a ng to section $I|\beta$. Sub- we arrive at

ontour integrals resented by x a lower index to the vanishing are allowed join- ed which have a



Fig. 7.

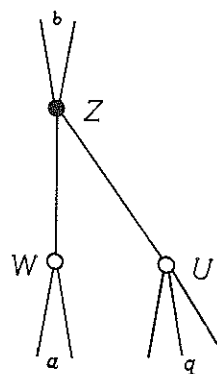

Fig. 8.

vertex at one end only. Such lines represent the singularities in the holomorphic functions $a(Z)$, $b(Z)$, ..., which enter into the integrals. In general the singularities of b will be separated into two sets, so two corresponding lines would emerge from the vertex representing Z , each of which stands for one set of singularities of b . We may, in fact, think in terms of particular functions b of the form

$$b = (A \cdot Z)^{-1-r} (B \cdot Z)^{-1-n+r}. \tag{4.5}$$

Then we may regard each of the lines with just one vertex as representing one of the two regions $A \cdot Z = 0, B \cdot Z = 0$. Thus the constant twistors A_α, B_α are represented by the missing vertices at the ends of the two lines. We call states describable by such functions (4.5) *elementary states*.

In fig. 7 the diagram representing the singularity structure for the scalar product (4.1) is depicted; the diagram in fig. 8 is what we have been led to for the singularity structure arising for our proposed interaction integrals. We can make our diagrams more explicit by labelling the lines with integers, where a single line labelled by r stands for a factor $(W \cdot Z)_{r+1}$. This can apply whether or not vertices appear at each end of the line, so that elementary states can be explicitly incorporated into the diagrams. For example, the scalar product between the two elementary states given

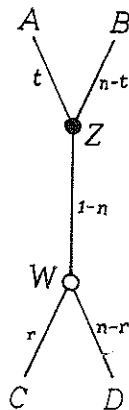

Fig. 9.

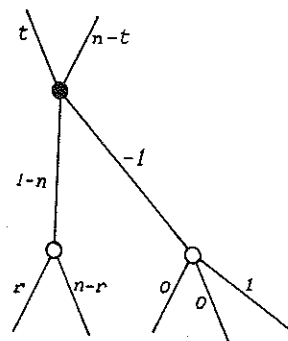

Fig. 10.

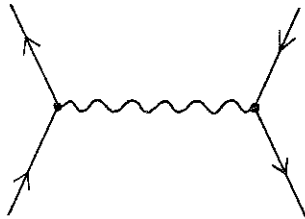

Fig. 11.

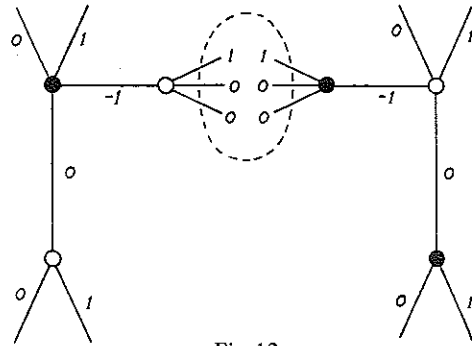

Fig. 12.

by $a(W) = (W \cdot C)_{r+1} (W \cdot D)_{n-r+1}$, $b(Z) = (A \cdot Z)_{t+1} (B \cdot Z)_{n-t+1}$, namely

$$\frac{1}{(2\pi i)^5} \oint (W \cdot C)_{r+1} (W \cdot D)_{n-r+1} (W \cdot Z)_{2-n} (A \cdot Z)_{t+1} (B \cdot Z)_{n-t+1} \mathcal{D}WZ$$

can be explicitly expressed by the diagram of fig. 9. Similarly (restricting attention to the electromagnetic case only) the proposed interaction integral could be depicted by the diagram of fig. 10, the electromagnetic field being described by the function $q(Z) = (E \cdot Z)_1 (F \cdot Z)_1 (G \cdot Z)_2$.

We may think of fig. 10 as describing some sort of electromagnetic vertex analogous to the one arising in standard Feynman theory. Then we could attempt to build up the diagrams corresponding to simple processes such as Möller or Compton scattering, for example.

Consider Möller scattering, the standard Feynman diagram being that of fig. 11 (except that here the electrons must be massless). We have been led to consider a twistor diagram of the sort indicated in fig. 12 where the arms in the dotted circle are to be "summed over" or contracted together in some other appropriate way. Because of the fact that the formula depicted diagrammatically in fig. 13 can be shown to be valid, it appears reasonable to perform our contraction so as to obtain fig. 14.

Now recall that we have employed the decomposition $H = H^+ + H^-$ in obtaining this diagram. Were we to repeat the discussion with H^- in place of H^+ , we should end up with the diagram of fig. 15. It may seem to be plausible to associate the twistor diagrams of figs. 14 and 15 with processes depicted in figs. 16a and 16b respectively, where the arrows denote helicity (in units of $\frac{1}{2}\hbar$) so the double arrow on the photon line occurs because the spin is $2 \times \frac{1}{2}\hbar$. We might then imagine that (corresponding to $H = H^+ + H^-$) the Möller scattering, fig. 11, could be expressible as the sum of two terms: fig. "16a plus 16b" or fig. "14 plus 15". However this presupposes that it is meaningful to express a virtual photon as a sum of two parts each of which has a well-defined helicity. This possibility is denied, in the conventional theory, owing to the fact that a virtual photon must be

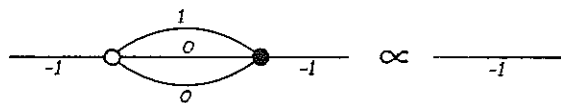

Fig. 13.

allowed to be
Particles with
the other ha
go against th
swers (for M
conventiona
This, in itsel
tainable as a
contributor
helicity²⁵.

In fact th
out that the
segment bea
integrals. On t
is fig. 17 and
angular depe
sive electron
11). It shoul
14 and 15. C
ing at all - 1
fig. 17 in rex

We are gratefu

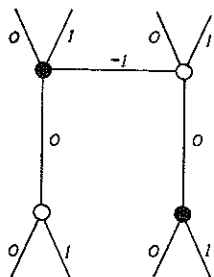
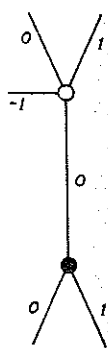

Fig. 14.

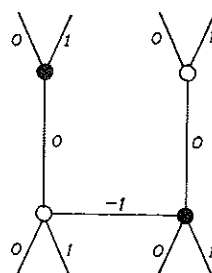

Fig. 15.

allowed to be "off the mass shell", i.e. to have a non-zero (and sometimes imaginary) rest-mass. Particles with non-zero rest-mass do not have a well-defined helicity. In the twistor approach, on the other hand, it would be unreasonable to allow photons to have a rest-mass, since this would go against the basic philosophy of the theory. Nevertheless the theory could not give sensible answers (for Möller scattering, for example) if it did not in some way reflect the fact which, in the conventional formalism, is accounted for by allowing virtual photons to be off the mass shell. This, in itself, renders it unlikely that the twistor computation of Möller scattering could be obtainable as a sum of two integrals, like those represented in figs. 14 and 15, in each of which the contribution due to a virtual photon appears to be identifiable, the photon having a well-defined helicity²⁵.

to the electrom-
m of fig. 10,
us to the one
s correspond-

cept that
of the sort
contracted
ed diagram-
ontraction so

is diagram.
diagram of
15 with pro-
n units of $\frac{1}{2}\hbar$
then imagine
ble as the sum
at it is meaning-
d helicity. This
ton must be

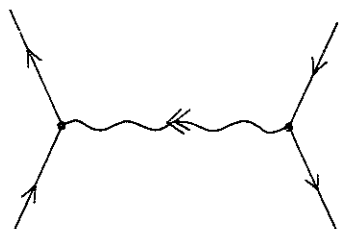

Fig. 16a.

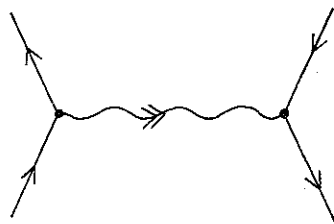

Fig. 16b.

In fact this is borne out by the actual computation of the integrals for figs. 14 and 15. It turns out that the answer in each case is simply proportional to that which it would have been, had the segment bearing "-1" been omitted. That is to say there is no interaction expressed by these integrals. On the other hand, we may envisage "superimposing" the two figs. 14 and 15. The result is fig. 17 and, remarkably, the integral it expresses actually gives, as we shall see later, the correct angular dependence for Möller scattering for massless electrons (i.e. the high energy limit for massive electrons) when the helicities of the two incoming particles are opposite (as indicated in fig. 11). It should be emphasized that at this stage there is no theoretical basis for superimposing figs. 14 and 15. On the other hand, no other reasonable way of modifying fig. 14 to obtain any scattering at all - let alone the correct Möller scattering - presented itself. The essential correctness of fig. 17 in representing a single photon exchange is further substantiated by the fact that it leads

²⁵We are grateful to B.S. DeWitt for drawing our attention to this fact.

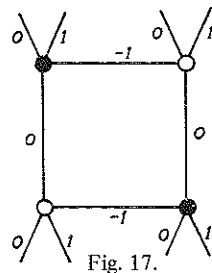

Fig. 17.

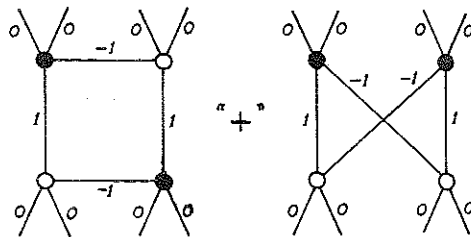

Fig. 18.

naturally to a similar expression (fig. 18) which correctly gives the angular dependence for the case of two spin zero massless particles exchanging a photon. Here we must add the results for two diagrams: in the first the spinless particles have opposite “helicities” and in the second, the same “helicity”. (It appears that, in the present theory, two separate “helicities” must be distinguished for a massless particle even when the spin is zero, but to obtain the physical answer, these “helicities” must be summed over.) It may be remarked at this point that recent work based on the results of section 5.3 has subsequently fully justified these twistor expressions. Finally, we shall also see later that fig. 17 leads directly to another diagram (fig. 30) which correctly gives the angular dependence for the high energy limit (i.e. massless particles) for Compton scattering.

4.2. Rules for diagrams

Accepting, for the moment, the correctness of fig. 17, we are led²⁶ to suggest some additional rules for the construction of our diagrams. First, let us insist that exactly *four* lines enter each vertex. In order to depict the scalar product (cf. fig. 7), we shall then require a *double* line for the internal segment. We adopt the convention that a single integer is to be attached to the double line as a whole. The line then stands for the factor $(W_\alpha Z^\alpha)_{r+2}$, where the twistors W_α and Z^α correspond to the vertices at the two ends of the line and r the integer attached to it. Similarly we shall occasionally need to use a triple line in a diagram, standing for the factor $(W_\alpha Z^\alpha)_{r+3}$. For completeness, a quadruple line standing for $(W_\alpha Z^\alpha)_{r+4}$ will also be allowed, but because of the rule that just four lines can terminate at each vertex, such lines must be disconnected from any other portions of the diagram. (Thus they would appear, if anything, to stand for disconnected vacuum processes.) In fact we must have $r = 0$ in this case because, in order for a diagram, constructed according to the above rules, to represent an integral which is homogeneous of degree zero (necessary if the integral is to be a genuine contour integral, invariant under continuous deformations of the contour), then we must require that: *the sum of the integers on all lines entering a given vertex is zero*. The notation for the diagrams is summarized in fig. 19.

The diagram for the scalar product can now be drawn as in fig. 20. Here the in- and out-states are explicitly expressed as the elementary states defined by $(W_\alpha A^\alpha)_1 (W_\beta B^\beta)_{n+1}$ and $(C_\alpha Z^\alpha)_1 (D_\beta Z^\beta)_{n+1}$ respectively. These elementary states have particular interest in that the fields are everywhere null, see section 2.3. If $n = 4$ and A^α, C_α are null twistors then they are linearized Robinson–Trautman null waves [31] of a particular kind, having wavefronts which are null cones with vertices on the null line A. If A and B are both at infinity we have a constant plane wave, while if A alone is at in-

finity we ha
ness singular
C ∩ D lie ei
[resp. negat

However
more gener:
sets of $a(z)$,
this reason,
we attach n

the scalar p
status of th
double line:
to the cont
by an S^1 (t
logical 3-sp
ropriate (twi
quired valu
“multiply”
we integrat

It appear
certain sens
separated li
ppropriate way.
Since the cc

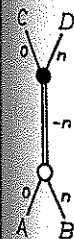
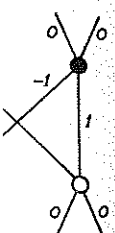

Fig. 20.

²⁶There are also some topological reasons, concerning the contour surfaces, for preferring diagrams constructed according to these rules. They are not conclusive, however.



$$\begin{aligned}
 \circ &: U_\alpha, V_\alpha, W_\alpha, \text{ etc.} \\
 \bullet &: X^\alpha, Y^\alpha, Z^\alpha, \text{ etc.} \\
 A \text{---} \bullet &: (A_\alpha Z^\alpha)_{k+1} \\
 B \text{---} \circ &: (B^\alpha W_\alpha)_{k+1}
 \end{aligned}
 \left. \vphantom{\begin{aligned} \circ \\ \bullet \\ A \text{---} \bullet \\ B \text{---} \circ \end{aligned}} \right\} \text{integrated over}$$

$$\begin{aligned}
 \circ \text{---} \bullet &: (W_\alpha Z^\alpha)_{k+1} \\
 \circ \text{---} \bullet &: (W_\alpha Z^\alpha)_{k+2} \\
 \circ \text{---} \bullet &: (W_\alpha Z^\alpha)_{k+3} \\
 \circ \text{---} \bullet &: (W_\alpha Z^\alpha)_4
 \end{aligned}$$

Fig. 19.

finity we have a plane wave of non-constant amplitude. In all these particular cases the fields possess singularities (possibly only at infinity); but if we require that in the C-picture the line AB or C ∩ D lie entirely in C⁺ [resp. C⁻] then we shall have a nowhere singular field which has positive [resp. negative] frequency (cf. section 2.3), cf. [4].

However, we shall not always want to represent our in- and out-states as elementary states. For more general situations (e.g. plane sinusoidal waves) it ceases to be useful to label the singularity sets of $a(z), \dots$ by two different integers; only their sum (= twice the spin) has significance. For this reason, we shall frequently represent an in- or out-state by one *double* external line, to which we attach merely a single integer n (this being twice the spin of the field). In fig. 21 we have drawn the scalar product according to these conventions. We should keep in mind, however, that the status of the internal double line (marked $-n$) is really rather different from that of the external double lines. The meaning of internal double lines has to do with the topological set-up with regard to the contours. Roughly speaking, we have to surround each singularity denoted by a single line by an S^1 (topological circle), each singularity denoted by an internal double line by an S^3 (topological 3-sphere) and each singularity denoted by an internal triple line by an S^5 , taking the appropriate (twisted?) topological product. Then, in effect, to get the dimension up or down to the required value for the contour (i.e. to $3v$ real dimensions, where v is the number of vertices) we must "multiply" or "divide" by the appropriate number of S^1 's. (This means that for the quadruple line we integrate over a $\mathbb{C}P^3 \cong S^7/S^1$.)

It appears to be consistent to regard a double line as a pair of single lines collapsed together in a certain sense. The equation represented by fig. 22 is in fact valid provided we interpret the two separated lines which join the same two vertices (on the left-hand side of the equation) in an appropriate way. We cannot simply adopt the product of factors $(W_\alpha Z^\alpha)_{1-a} (W_\beta Z^\beta)_{b+1}$ in the integral, since the contour is supposed to pass "between" the singularity represented by each factor. Since

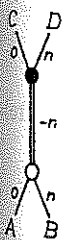

Fig. 20.

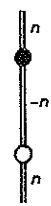

Fig. 21.

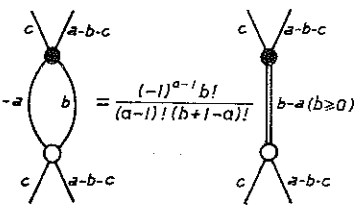

Fig. 22.

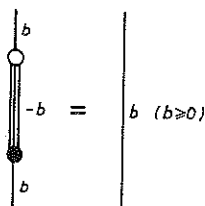

Fig. 23.

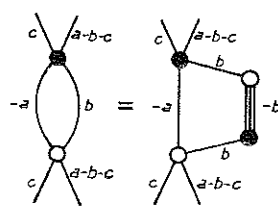

Fig. 24.

ce for the case
s for two dia-
the same
distinguished
these "helici-
d on the re-
, we shall also
the angular

e additional
nter each
le line for the
he double
and Z^α cor-
milarly we
 $\alpha)_{r+3}$. For
use of the
d from any
connected
gram, cons-
s of degree
ntinuous de-
ll lines enter-
ing

nd out-states
($C_\alpha Z^\alpha$)_i ($D_\beta Z^\beta$)_{n+1}
everywhere null,
on-Trautman
rtices on the
alone is at in-
according to these

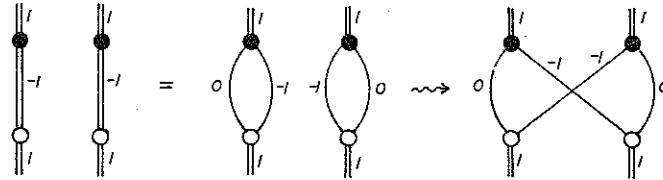

Fig. 25.

the two factors here have the *same* singularity (namely $W_\alpha Z^\alpha = 0$) it is clearly impossible for the contour to pass between them. However we can invoke the relation expressed in fig. 23 in order to “free” these singularities from one another. The meaning of the left-hand side of fig. 22 is then expressed in fig. 24, for which a perfectly well-defined contour does exist. We should finally remark that in order to get the numerical factors simple in these expressions²⁷ it is convenient to adopt a suitable multiplying factor before the integral representing each diagram. We shall take this factor to be $(2\pi i)^{-3v+r}$ where v is the number of vertices and r is the number of extra lines which have to be drawn which make the multiple lines multiple (i.e. the smallest number of lines which must be erased so that no multiple lines remain). Thus the integral for the right-hand side of fig. 22 will be preceded by the factor $(2\pi i)^{-5}$, that for the left-hand side of fig. 23 by $(2\pi i)^{-4}$, and that for the right-hand side of fig. 24 by $(2\pi i)^{-10}$.

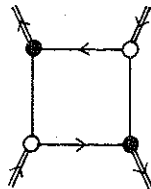

Fig. 26.

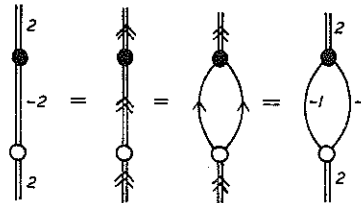

Fig. 27.

It is worth remarking here on a curious way of interpreting the electromagnetic interaction expressed in fig. 17. Let us imagine two charged zero-mass spin $\frac{1}{2}$ particles of positive helicity coming together. If each particle emerges without having interacted, then the twistor diagram is that depicted at the far left in fig. 25, namely two scalar product diagrams multiplied together. According to fig. 22, we can re-express the situation by the diagram in the centre of fig. 25. Still there is no interaction. But if we imagine that the two lines marked “-1” are subject to some form of Fermi (or Bose) statistics, then we must expect to have to add or subtract a contribution in which the lines marked “-1” cross over – as depicted at the extreme right of fig. 25. But this resulting figure is just that which we have used, in fig. 17, to denote a single photon exchange between the two particles (except that the photon lines are now depicted as crossing over – simply because the helicities of the two incoming particles have been chosen to be the same, rather than opposite). Thus, the twistor formalism seems to be suggesting that the electromagnetic interaction may be some form of manifestation of Fermi (?) statistics as applied to the individual twistor scalar product lines which occur in the diagrams.

²⁷We are grateful to A. Qadir for evaluating several of these integrals in detail [32].

The integ
helicity. Th
black vertex
lines termin
grams const
leaving it. I
that the exc
opposite. It
by pairs of t
interaction,
Observe tha
rather than
the photon
type of segn
fig. 27. The
with the hel
does not ha
In this th
the Feynma
separate par
This seems
then, are we
photon line
may attemp
yet assembl

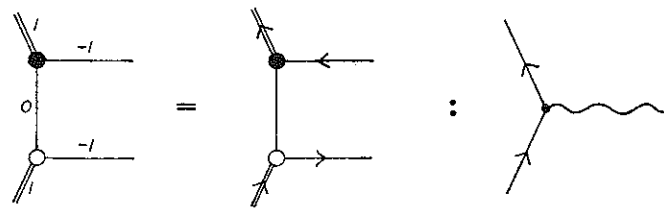

Fig. 28.

The integers which occur on the lines in the twistor diagrams may be interpreted as denoting helicity. Thus the integer r appearing on a line indicates that a helicity $\frac{1}{2}r$ is proceeding from the black vertex to the white vertex which terminate the line. The fact that the integers on all the lines terminating at any one vertex must sum to zero gives us a *helicity conservation law* for diagrams constructed in this way: the total helicity entering the diagram must equal the total helicity leaving it. In fig. 26 the helicities involved in the photon exchange of fig. 17 are indicated. Note that the exchanged photon is represented by two disconnected lines, the indicated helicities being opposite. It appears to be a characteristic feature of the twistor theory that particles are represented by *pairs* of twistor scalar product lines. In the case of a free photon entering and leaving without interaction, we can represent the scalar product diagram in either of the ways indicated in fig. 27. Observe that when the two central lines are separated, the helicities proceed in the same direction, rather than in the opposite direction as appears to be the case for a virtual photon exchange. In the photon exchange, the two segments bearing “-1” may, perhaps, be thought of as the “same” type of segment as those into which the free photon appears to split in the right-hand diagram of fig. 27. The difference is that in the photon exchange, the lines have become quite disconnected, with the helicities working in opposition rather than together. Thus, the virtual photon, as a whole, does not have (as it should not have) a well-defined helicity.

In this theory we may think of the twistor situation depicted in fig. 28 as playing the part of the Feynman vertex of the conventional theory. However, here the photon line is split into two separate parts which cannot by themselves be assembled to yield a single external photon line. This seems to reflect the fact that a single Feynman vertex represents a virtual process. But how, then, are we to represent real processes built up from several Feynman vertices in which external photon lines may be present? Let us consider the simplest case, namely Compton scattering. We may attempt to make the correspondence indicated in fig. 29. The external photon lines are not yet assembled correctly, however, since we need to produce double lines numbered “+2” to re-

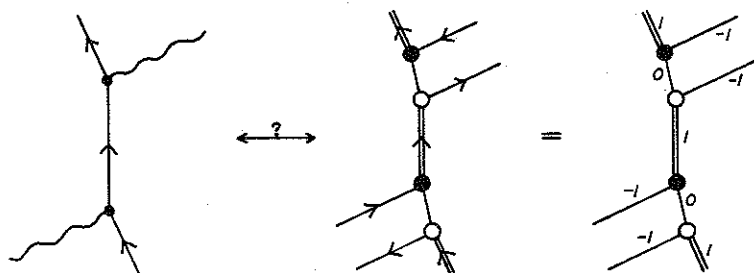
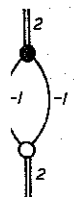

Fig. 29.

ble for the
3 in order
g. 22 is then
finally re-
nient to
shall take
extra lines
ber of lines
-hand side
y $(2\pi i)^{-4}$,



eraction ex-
licity coming
is that de-
er. According
there is no
rm of Fermi
which the
esulting fig-
etween the
y because
an opposite).
on may be
scalar pro-

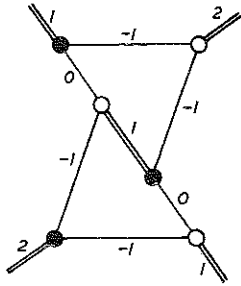

Fig. 30.

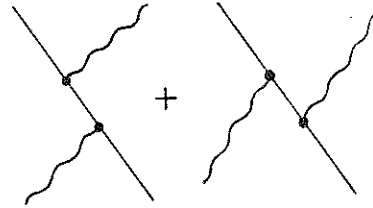
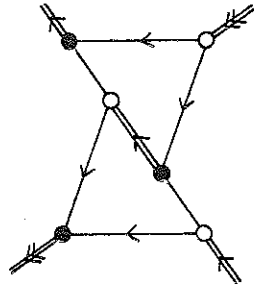

Fig. 31.

present external photons. It becomes clear that to achieve this according to the rules for the twistor diagrams we must assemble each external photon using one twistor line from *each* "Feynman vertex". The result is given in fig. 30. Note that the two photons attach themselves to the electron in a way which does not allow one to say that one interaction occurred completely "before" the other one. Thus, instead of simply describing the Feynman diagram in fig. 29, we must think of fig. 30 as describing the complete process indicated in fig. 31, except that we have singled out a particular helicity state for the photon as well as for the (massless) electron. (Of course, in the conventional formalism, these two diagrams must be added in any case, in order to obtain a meaningful answer.) Remarkably enough, computation of the twistor integral of fig. 30 does in fact yield the correct angular dependence for Compton scattering of massless (i.e. high energy limit) electrons.

4.3. *Evaluation of diagrams using elementary states*

So far we have not attempted to *compute* any of the twistor integrals. Not surprisingly these computations can be difficult to perform. The integrals are taken over manifolds (which are themselves not always easy to locate) of rather large dimension. Also, twistor diagrams involve "closed loops" even for the simplest processes where the conventional formalism yields "trees". It often turns out that indirect methods of evaluating the integrals must be used if the computations are not to get out of hand. But let us just start by evaluating a few very simple twistor diagrams, without regard to the question of physical meaningfulness. The first diagram we shall evaluate is that of fig. 32. However, before doing so we shall introduce some pictorial notation which will help us keep track of the contractions and skewing of the twistors involved in the integrals (cf. [1]). This is as follows:

$\begin{array}{c} W \\ | \\ A \end{array}$ stands for $W_\alpha A^\alpha$

$\begin{array}{c} | \\ | \\ | \\ | \end{array}$ stands for $\epsilon^{\alpha\beta\gamma\delta}$, $\begin{array}{c} \text{---} \\ \text{---} \\ \text{---} \\ \text{---} \end{array}$ for $\epsilon_{\alpha\beta\gamma\delta}$, $\begin{array}{c} | \\ | \end{array}$ for $2\delta_\rho^{[\alpha}\delta_\sigma^{\beta]}$, $\begin{array}{c} | \\ | \\ | \\ | \end{array}$ for $6\delta_\rho^{[\alpha}\delta_\sigma^{\beta}\delta_\tau^{\gamma]}$.

R. Pe
so
Note that
As an exam
I
the contour
Put $\int_A^W = a$
Now $\int_A^{dW} =$
D

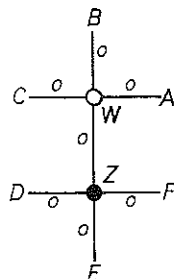

Fig. 33.

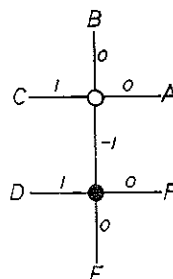

Fig. 34.

$$I_1 = -\frac{1}{(2\pi i)^3} \oint \frac{d\alpha \wedge d\beta \wedge d\gamma}{\alpha\beta\gamma} \frac{\overline{A B C D}}{\overline{A B C D}} = -\frac{1}{\overline{A B C D}} \quad (4.8)$$

Similarly we may evaluate fig. 33 which gives

$$I_2 = \frac{1}{(2\pi i)^6} \oint \frac{DWZ}{\overline{W W W W D E F}} = \oint \frac{-DZ}{\overline{A B C Z Z Z Z}} \frac{1}{(2\pi i)^3} \quad (4.9)$$

$$= \frac{-1}{\overline{A B C D E F}} = \frac{1}{\overline{D E F}} \quad (4.9)$$

Now we remark that the value of fig. 34 may be found from that of fig. 33 by differentiating the value of fig. 33 with respect to C^α and selecting the coefficient of D_α in the answer (as can be seen from an integration by parts of the integrand of fig. 34). The value of fig. 34 is thus

$$\frac{\overline{E F}}{\overline{A B}} \left(\frac{\overline{D E F}}{\overline{A B C}} \right)^2 = I_3 \quad (4.10)$$

By combining these processes we can evaluate any tree diagram with single external lines, which has non-negative integers on its external lines.

For fig. 34

I_4

where the co-
n. (Altern
product of S
G, H does n
 R_α, S_α , wh
 $Q = G \cap H \cap$

R
|
 A

put

W
|
 A

The S^2 integ

ψ

Since ψ, χ
of them mus

∂V

whence

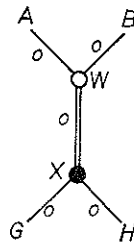

Fig. 35.

For fig. 35 we have

$$(4.8) \quad I_4 = \frac{1}{(2\pi i)^5} \oint \frac{DWX}{\begin{matrix} W & W & (W)^2 & G & H \\ \downarrow & \downarrow & \downarrow & \downarrow & \downarrow \\ A & B & (X) & X & X \end{matrix}} \quad (4.11)$$

where the contour integration is made up of four S^1 integrals and one S^2 integral taken in succession. (Alternatively the surface of integration can involve an S^3 explicitly, this being a twisted product of S^1 with S^2 .) Assume that in the C-picture the line of intersection of the two planes, G, H does not meet the line AB (otherwise I_4 becomes infinite). Choose auxiliary twistors $P^\alpha, Q^\alpha, R_\alpha, S_\alpha$, where for simplicity, R and S are general planes through AB , and $P = G \cap H \cap S, Q = G \cap H \cap R$. Then, normalizing appropriately, we have

$$(4.9) \quad \begin{matrix} R & R & R & S & S & S & G & H & G & H \\ \downarrow & \downarrow & \downarrow & \downarrow & \downarrow & \downarrow & \downarrow & \downarrow & \downarrow & \downarrow \\ A & B & Q & A & B & P & P & P & Q & Q \end{matrix} = 0, \quad \begin{matrix} R & S \\ \downarrow & \downarrow \\ P & Q \end{matrix} = 1. \quad (4.12)$$

Put

$$\begin{matrix} W \\ \downarrow \\ A \end{matrix} = \alpha, \quad \begin{matrix} W \\ \downarrow \\ B \end{matrix} = \beta, \quad \begin{matrix} W \\ \downarrow \\ P \end{matrix} = \psi, \quad \begin{matrix} W \\ \downarrow \\ Q \end{matrix} = \chi, \quad \begin{matrix} G \\ \downarrow \\ X \end{matrix} = \gamma, \quad \begin{matrix} H \\ \downarrow \\ X \end{matrix} = \eta, \quad \begin{matrix} R \\ \downarrow \\ X \end{matrix} = \rho, \quad \begin{matrix} S \\ \downarrow \\ X \end{matrix} = \sigma.$$

The S^2 integration involves the variables ψ, χ, ρ, σ given by

$$\psi = e^{i\varphi} \cos \frac{1}{2}\theta, \quad \chi = \sin \frac{1}{2}\theta, \quad \rho = e^{-i\varphi} \cos \frac{1}{2}\theta, \quad \sigma = \sin \frac{1}{2}\theta.$$

Since ψ, χ, ρ, σ involve only two independent variables, the wedge product of more than two of them must vanish. It follows that

$$(4.10) \quad DWX = \left(\begin{matrix} G & H & R & S \\ \downarrow & \downarrow & \downarrow & \downarrow \\ A & B & P & Q \end{matrix} \right)^{-1} d\alpha \wedge d\beta \wedge (\psi d\chi - \chi d\psi) \wedge d\gamma \wedge d\eta \wedge (\rho d\sigma - \sigma d\rho)$$

whence

nes, which

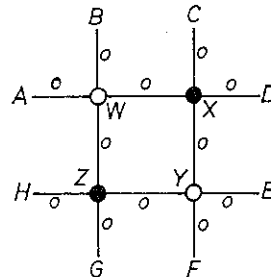

Fig. 36.

$$I_4 = \frac{36}{(2\pi i)^5} \oint \frac{\begin{array}{|c|c|c|} \hline GH & RS & \\ \hline \hline AB & PQ & \\ \hline \end{array} d\alpha \wedge d\beta \wedge (\psi d\chi - \chi d\psi) \wedge d\gamma \wedge d\eta \wedge (\rho d\sigma - \sigma d\rho)}{\alpha\beta\gamma\eta \left(\begin{array}{|c|c|c|} \hline GH & RS & \\ \hline Z & & \\ W & & \\ \hline AB & PQ & \\ \hline \end{array} \right)^2}$$

$$= \frac{\begin{array}{|c|c|} \hline GH & \\ \hline AB & \\ \hline \end{array}}{2\pi i} \oint \frac{(\psi d\chi - \chi d\psi) \wedge (\rho d\sigma - \sigma d\rho)}{\left(\begin{array}{|c|c|} \hline R & S \\ \hline X & GH \\ W & AB \\ \hline P & Q \\ \hline \end{array} \right)^2} = \left(\begin{array}{|c|c|} \hline GH & \\ \hline AB & \\ \hline \end{array} \right)^{-1} \oint \frac{(\psi d\chi - \chi d\psi) \wedge (\rho d\sigma - \sigma d\rho)}{(\rho\psi + \sigma\chi)^2}$$

since the part of $\begin{array}{|c|c|c|} \hline W & & \\ \hline AB & PQ & \\ \hline \end{array}$ independent of $\alpha = \begin{array}{|c|} \hline W \\ \hline A \end{array}$ is $-\frac{1}{2} \begin{array}{|c|c|} \hline W & A \\ \hline B & PQ \\ \hline \end{array}$, etc., and where (4.12) has been made use of. Finally, integrating over the spherical polar variables θ and φ , we obtain

$$I_4 = \left(\begin{array}{|c|c|} \hline GH & \\ \hline AB & \\ \hline \end{array} \right)^{-1} \tag{4.13}$$

Fig. 36 provides a somewhat more complicated example. We have

$$I_5 = \frac{1}{(2\pi i)^{12}} \oint \frac{\mathcal{D}WXYZ}{\begin{array}{|c|c|c|c|c|c|c|c|c|c|} \hline W & W & W & C & D & Y & Y & Y & Y & G & H & W \\ \hline | & | & | & | & | & | & | & | & | & | & | & | \\ \hline A & B & X & X & X & X & E & F & Z & Z & Z & Z \\ \hline \end{array}} = \frac{1}{(2\pi i)^9} \oint \frac{\mathcal{D}XYZ}{\begin{array}{|c|c|c|c|c|c|c|c|} \hline & & & C & D & Y & Y & Y & Y & G & H \\ \hline | & | & | & | & | & | & | & | & | & | & | \\ \hline Z & A & B & X & X & X & X & E & F & Z & Z & Z \\ \hline \end{array}}$$

R

Write

Introd

Then

Taking t
we obtai

$$= \frac{1}{(2\pi i)^6} \oint \frac{\mathcal{D}YZ}{\begin{array}{c} \overline{\quad\quad\quad} \\ \begin{array}{cccc} Z & A & B & \end{array} \\ \overline{\quad\quad\quad} \\ \begin{array}{cccc} C & D & Y & \end{array} \\ \overline{\quad\quad\quad} \\ \begin{array}{cccc} Y & Y & Y & G & H \\ E & F & Z & Z & Z \end{array} \end{array}} = \frac{1}{(2\pi i)^3} \oint \frac{\mathcal{D}Z}{\begin{array}{c} \overline{\quad\quad\quad} \\ \begin{array}{cccc} Z & A & B & \end{array} \\ \overline{\quad\quad\quad} \\ \begin{array}{cccc} C & D & E & F \end{array} \\ \overline{\quad\quad\quad} \\ \begin{array}{cccc} G & H & Z & Z & Z \end{array} \end{array}}$$

Write

$$\begin{array}{c} \circ \\ \curvearrowright \end{array} = \begin{array}{c} \overline{\quad\quad\quad} \\ \begin{array}{cccc} A & B & C & D & E & F \end{array} \\ \overline{\quad\quad\quad} \end{array}$$

Introduce auxiliary twistors R_α, S_α and put

$$\frac{G}{Z} = \gamma, \quad \frac{H}{Z} = \eta, \quad \frac{R}{Z} = \rho, \quad \frac{S}{Z} = 1.$$

Then

$$\begin{aligned} I_5 &= \frac{1}{(2\pi i)^3} \oint \frac{\mathcal{D}Z}{\begin{array}{c} \circ \\ \curvearrowright \\ \begin{array}{cccc} Z & Z & Z & Z \end{array} \end{array}} \frac{\mathcal{D}Z}{\begin{array}{c} \overline{\quad\quad\quad} \\ \begin{array}{cccc} G & H & Z & Z \end{array} \end{array}} = \frac{36}{(2\pi i)^3} \oint \frac{-d\gamma \wedge d\eta \wedge d\rho}{\begin{array}{c} \overline{\quad\quad\quad} \\ \begin{array}{cccc} G & H & R & S \\ G & H & R & S \\ Z & Z & Z & Z \end{array} \end{array}} \frac{\mathcal{D}Z}{\begin{array}{c} \overline{\quad\quad\quad} \\ \begin{array}{cccc} G & H & R & S \\ G & H & R & S \\ Z & Z & Z & Z \end{array} \end{array}} \gamma \eta \\ &= \frac{9}{(2\pi i)^2} \oint \frac{d\eta \wedge d\rho}{\begin{array}{c} \overline{\quad\quad\quad} \\ \begin{array}{cccc} H & R & S & Z \\ H & R & S & Z \\ G & Z & G & Z \end{array} \end{array}} \frac{\mathcal{D}Z}{\begin{array}{c} \overline{\quad\quad\quad} \\ \begin{array}{cccc} G & H & R & S \\ G & H & R & S \\ Z & Z & Z & Z \end{array} \end{array}} = \frac{-1}{2\pi i} \oint \frac{d\rho}{\begin{array}{c} \overline{\quad\quad\quad} \\ \begin{array}{cccc} R & S & Z & G \\ R & S & Z & G \\ G & H & Z & G \end{array} \end{array}} \frac{\mathcal{D}Z}{\begin{array}{c} \overline{\quad\quad\quad} \\ \begin{array}{cccc} G & H & R & S \\ G & H & R & S \\ Z & Z & Z & Z \end{array} \end{array}} \end{aligned}$$

$\frac{\rho d\sigma - \sigma d\rho}{\chi^2}$

4.12) has

obtain

$$(4.13) \quad = \frac{1}{2\pi i} \oint \left[d\rho \frac{\mathcal{D}Z}{\begin{array}{c} \overline{\quad\quad\quad} \\ \begin{array}{cccc} G & H & R & S \\ G & H & R & S \\ Z & Z & Z & Z \end{array} \end{array}} \right] / \left[\rho^2 \frac{\mathcal{D}Z}{\begin{array}{c} \overline{\quad\quad\quad} \\ \begin{array}{cccc} S & G & H & Z \\ S & G & H & Z \\ G & H & R & Z \end{array} \end{array}} \frac{\mathcal{D}Z}{\begin{array}{c} \overline{\quad\quad\quad} \\ \begin{array}{cccc} G & H & S & Z \\ G & H & S & Z \\ Z & Z & Z & Z \end{array} \end{array}} - \rho \left(\frac{\mathcal{D}Z}{\begin{array}{c} \overline{\quad\quad\quad} \\ \begin{array}{cccc} R & G & H & Z \\ R & G & H & Z \\ G & H & S & Z \end{array} \end{array}} \frac{\mathcal{D}Z}{\begin{array}{c} \overline{\quad\quad\quad} \\ \begin{array}{cccc} G & H & S & Z \\ G & H & S & Z \\ Z & Z & Z & Z \end{array} \end{array}} + \right. \\ \left. \frac{\mathcal{D}Z}{\begin{array}{c} \overline{\quad\quad\quad} \\ \begin{array}{cccc} S & G & H & Z \\ S & G & H & Z \\ G & H & R & Z \end{array} \end{array}} \frac{\mathcal{D}Z}{\begin{array}{c} \overline{\quad\quad\quad} \\ \begin{array}{cccc} G & H & R & Z \\ G & H & R & Z \\ Z & Z & Z & Z \end{array} \end{array}} \right) + \frac{\mathcal{D}Z}{\begin{array}{c} \overline{\quad\quad\quad} \\ \begin{array}{cccc} R & G & H & Z \\ R & G & H & Z \\ G & H & R & Z \end{array} \end{array}} \frac{\mathcal{D}Z}{\begin{array}{c} \overline{\quad\quad\quad} \\ \begin{array}{cccc} G & H & R & Z \\ G & H & R & Z \\ Z & Z & Z & Z \end{array} \end{array}} \right].$$

Taking the contour to pass between the two zeros of the quadratic expression in the denominator we obtain, after some manipulation,

$$I_5 = (2ab + 2bc + 2ca - a^2 - b^2 - c^2)^{1/2}$$

$\begin{array}{cccc} Y & Y & Y & G & H \\ E & F & Z & Z & Z \end{array}$

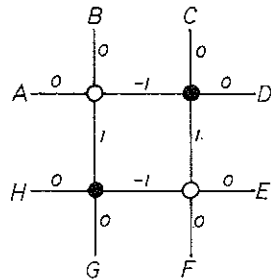

Fig. 37.

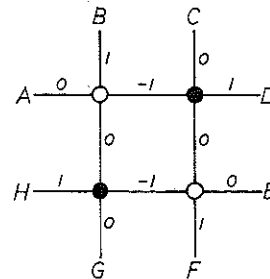

Fig. 38.

where

$$a = \frac{1}{4} \begin{array}{c} C D \\ | | \\ A B \end{array} \begin{array}{c} G H \\ | | \\ E F \end{array}, \quad b = \frac{1}{4} \begin{array}{c} G H \\ | | \\ A B \end{array} \begin{array}{c} C D \\ | | \\ E F \end{array}, \quad c = \frac{1}{4} \begin{array}{c} C D G H \\ | | | | \\ A B E F \end{array}.$$

It can be shown that fig. 37 leads to a value

$$I_6 = \left(1 + \frac{a - c}{b}\right) I_5.$$

Then, one has for fig. 38 (high energy limit of Möller scattering in terms of elementary states)

$$I_7 = \frac{\partial^2}{\partial D^\nu \partial F_\nu} \frac{\partial^2}{\partial B_\mu \partial H^\mu} I_6. \tag{4.17}$$

4.4. Momentum state diagrams

Finally we want to consider states, which are momentum eigenstates, represented by

$$f_n(Z) = \frac{\exp(K \cdot Z / B \cdot Z)}{(A \cdot Z)(B \cdot Z)^{n+1}} \tag{4.18}$$

where A and B are generators of the null cone at infinity and K a null line meeting A . Momentum states are needed in order to obtain direct comparisons with the usual results of quantum mechanics, since elementary states are difficult to interpret. (4.18) represents a circularly polarised plane wave in the direction of A . We have²⁸

$$\begin{aligned} \phi_0(Y, Z) &= \frac{1}{2\pi i} \oint f(\lambda Z + Y) d\lambda \\ &= \frac{(A \cdot Z)^n \exp(AK \cdot P / AB \cdot P)}{(AB \cdot P)^{n+1}} \end{aligned} \tag{4.19}$$

²⁸Where $AB \cdot P = A_\alpha B_\beta P^{\alpha\beta}$.

R. and $P_{\alpha\beta}$ (i. and if A_α is null, with $-ik_\alpha x^\alpha$ and

(For Max Now we no longer To calcula we can pr i) $I^{\alpha\beta} \partial/$

since $I^{\alpha\beta} A$ ii) $I_{\alpha\beta} Z^\beta$

This is bec plication t due to (A- iii) $Z^\alpha I^\beta$

Applying find the ef Now we we abbrevi to the mor That ϕ_0 , th concerning

and $P_{\alpha\beta}$ (i.e. $x^Q Q'$) represents the point of intersection of Y and Z .²⁹ We have $I_{\alpha\beta} = A_\alpha B_\beta - A_\beta B_\alpha$ and if $A_\alpha = (0, \kappa^{A'})$, $B_\alpha = (0, \tau^{A'})$, $K_\alpha = (\bar{\kappa}_A, 0)$ and $\epsilon^{A'B'} = \kappa^{A'} \tau^{B'} - \kappa^{B'} \tau^{A'}$ ($\kappa_A \tau^{A'} = 1$). The field is null, with principal null direction that of A , as $A \cdot Z$ gives a simple pole. $AK:P = -i\bar{\kappa}_Q \kappa_Q x^Q Q' = -ik_a x^a$ and

$$\begin{aligned} \phi_0(Y, Z) &= (\kappa^{A'} \pi_{A'}) \exp(-ik_a x^a) \\ \phi^{A'B' \dots L'} &= \kappa^{A'} \dots \kappa^{L'} \exp(-ik_a x^a). \end{aligned}$$

(For Maxwell fields this expression was given in section 1.2.)

Now we wish to evaluate figs. 17 and 30 using momentum states. In this case the contours will no longer be well-defined as they become pinched. We expect, and find, a δ -function singularity. To calculate the scatterings given by figs. 17 and 30, i.e. to find the coefficient of the δ -function, we can proceed formally by making use of the operators

i) $I^{\alpha\beta} \partial/\partial Z^\beta$. This acts on f_n to give

$$\begin{aligned} I^{\alpha\beta} \frac{\partial}{\partial Z^\beta} f_n &= \frac{I^{\alpha\beta} K_\beta}{(B \cdot Z)} \frac{\exp(K \cdot Z/B \cdot Z)}{(A \cdot Z)(B \cdot Z)^{n+1}} \\ &= \frac{\bar{A}^\alpha}{(B \cdot Z)} \frac{\exp(K \cdot Z/B \cdot Z)}{(A \cdot Z)(B \cdot Z)^{n+1}} = \bar{A}^\alpha f_{n+1} \end{aligned} \tag{4.20}$$

since $I^{\alpha\beta} A_\beta = I^{\alpha\beta} B_\beta = 0$.

ii) $I_{\alpha\beta} Z^\beta$. This yields

$$\begin{aligned} I_{\alpha\beta} Z^\beta f_n &= \{A_\alpha (B_\beta Z^\beta) - B_\alpha (A_\beta Z^\beta)\} f_n \\ &= A_\alpha (B_\beta Z^\beta) f_n \quad \text{in integrals,} \\ &= A_\alpha f_{n-1}. \end{aligned} \tag{4.17}$$

This is because $\oint f_n(A \cdot Z) \partial Z = 0$, since the contour separates the singularities of A and B and multiplication by $(A \cdot Z)$ enables us to contract the contour through what was formerly the singularity due to $(A \cdot Z)^{-1}$.

iii) $Z^\alpha I^{\beta\gamma} \partial f_n / \partial Z^\gamma$. This is represented by

$$\left(Z^\alpha I^{\beta\gamma} \frac{\partial}{\partial Z^\gamma} + Y^\alpha I^{\beta\gamma} \frac{\partial}{\partial Y^\gamma} \right) \phi_0(Y, Z) = A_\lambda P^{\lambda\alpha} \bar{A}^\beta \phi_0 \tag{4.22}$$

$$\leftrightarrow \left(\frac{-i\kappa_C x^{AC} \bar{\kappa}^B}{0} \mid \frac{\kappa_A \bar{\kappa}^B}{0} \right) \phi_0 = \left(\frac{\bar{\kappa}^B \partial \phi_0 / \partial \bar{\kappa}_A}{0} \mid \frac{\bar{\kappa}^B \kappa_A \phi_0}{0} \right). \tag{4.23}$$

Applying operator iii) and its dual version to two connected vertices and contracting over α , we find the effect is to multiply the numerator of the integrand by $(W \cdot Z)$ changing $(W \cdot Z)_a$ to $-a(W \cdot Z)_{a-1}$.

Now we want to evaluate the cross-sections arising from diagrams of the form of fig. 39a, which we abbreviate to fig. 39b. Here the states are labelled by the spinors $\kappa^{A'}$, ρ^A , $\sigma^{A'}$, τ^A corresponding to the momentum vectors:

²⁹That ϕ_0 , the null-datum on the null cone at infinity, represents the full field, is proved in [11, 33]; see also the discussion in [21] concerning such waves and their representation.

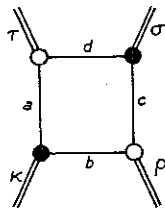

Fig. 39a.

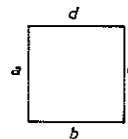

Fig. 39b.

$$k^a = \bar{\kappa}^A \kappa^{A'}, \quad r^a = \rho^A \bar{\rho}^{A'}, \quad s^a = \bar{\sigma}^A \sigma^{A'}, \quad t^a = \tau^A \bar{\tau}^{A'}$$

Using operator i) and integrating by parts we find

$$\bar{\kappa}^A \begin{array}{|c|} \hline d \\ \hline a \quad \square \quad c \\ \hline b \end{array} = -\tau^A \begin{array}{|c|} \hline d \\ \hline a+1 \quad \square \quad c \\ \hline b \end{array} - \rho^A \begin{array}{|c|} \hline d \\ \hline a \quad \square \quad c \\ \hline b+1 \end{array} \tag{4.24}$$

Hence

$$a+1 \begin{array}{|c|} \hline d \\ \hline \square \quad c \\ \hline b \end{array} = - \left(\frac{\bar{\kappa} \cdot \rho}{\tau \cdot \rho} \right) \begin{array}{|c|} \hline d \\ \hline \square \quad c \\ \hline b \end{array} \tag{4.25}$$

Using this formula we find we need only evaluate one of the box diagrams.

Now, let us consider (say) the case when k^a and s^a are incoming and define

$$\delta = \delta(\kappa \bar{\kappa} - \rho \bar{\rho} + \sigma \bar{\sigma} - \tau \bar{\tau}) = \delta(k^a - r^a + s^a - t^a)$$

Define the relation \approx by

$$\theta \approx \psi \Leftrightarrow \theta \delta = \psi \delta,$$

i.e. " $\theta \approx \psi$ " means $\theta - \psi$ vanishes whenever $k^a + s^a = r^a + t^a$. Then

$$\alpha: = -\bar{\kappa} \cdot \rho / \tau \cdot \rho \approx -\bar{\tau} \cdot \sigma / \kappa \cdot \sigma = : \alpha'$$

$$\beta: = -\bar{\sigma} \cdot \tau / \rho \cdot \tau \approx -\bar{\rho} \cdot \kappa / \sigma \cdot \kappa = : \beta'$$

$$\lambda: = -\bar{\kappa} \cdot \tau / \rho \cdot \tau \approx -\bar{\rho} \cdot \sigma / \kappa \cdot \sigma = : \lambda'$$

$$\mu: = -\bar{\sigma} \cdot \rho / \tau \cdot \rho \approx -\bar{\tau} \cdot \kappa / \sigma \cdot \kappa = : \mu'$$

The variables $\alpha, \beta, \lambda, \mu$ are related to the Mandelstam variables s, t, u used in quantum mechanical scattering calculations. The extra information conveyed by the extra variable relates to the phase (in its connection with the spin).

Now if

$$\begin{array}{ccc} & 0 & \\ 0 & \square & 0 = \delta \\ & 0 & \end{array}$$

then

$$\begin{array}{ccc} & d & \\ a & \square & c = \alpha^a \beta^b \lambda^c \mu^d \delta. \\ & b & \end{array} \tag{4.26}$$

(4.24)

To prove the supposition here, we apply (4.22, 4.23) to $\begin{array}{ccc} & 0 & \\ & \square & 0 = \chi \\ & 0 & \end{array}$ and find

$$\tau_A \partial \chi / \partial \bar{\kappa}_A + \kappa_A \partial \chi / \partial \bar{\tau}_A = 0, \text{ etc.} \tag{4.27}$$

(4.25)

Hence $\begin{array}{ccc} & 0 & \\ & \square & \\ & 0 & \end{array}$ is a function of $(\kappa \bar{\kappa} - \rho \bar{\rho} + \sigma \bar{\sigma} - \tau \bar{\tau})$ alone and it must be the δ -function to ensure conservation of momentum.

To cope with diagrams of the form

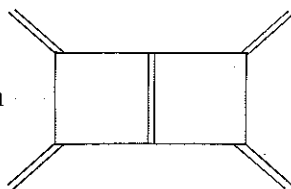

is not so simple. We can set up a

series of relations such as

$$\tau \begin{array}{|c|c|} \hline \text{up 1} & \\ \hline \end{array} - \tau \begin{array}{|c|c|} \hline \text{up 1} & \text{down 1} \\ \hline \text{up 1} & \\ \hline \end{array} = \rho \begin{array}{|c|c|} \hline \text{up 1} & \text{down 1} \\ \hline & \text{up 1} \\ \hline \end{array} - \bar{\kappa} \begin{array}{|c|c|} \hline & \\ \hline \end{array}$$

and differential operator relations analogous to (4.20)–(4.23) and eventually eliminate to derive a (soluble) differential equation. The result is

um mechanical
s to the phase

$$\begin{aligned}
 &= \alpha^{a-e} \beta^b \lambda^c \mu^d \left\{ \sum_r \binom{a}{r+e} \binom{b}{r} \left(\frac{\lambda\mu}{\alpha\beta} \right)^r \right\} \delta \tag{4.28} \\
 &= \alpha^{a-e} \beta^b \lambda^c \mu^d \left(1 - \frac{\lambda\mu}{\alpha\beta} \right)^{b+a+1} \left\{ \sum_r \binom{a+r}{r+e} \binom{b+r+e}{r} \left(\frac{\lambda\mu}{\alpha\beta} \right)^r \right\} \delta
 \end{aligned}$$

where $\binom{a}{b}$ is the usual binomial coefficient.

To find the differential cross-sections from these amplitudes we must take the squares of their moduli. We may verify that

$$\bar{\alpha} = \frac{\beta'}{\alpha'\beta' - \lambda'\mu'}, \quad \bar{\lambda} = \frac{\mu'}{\lambda'\mu' - \alpha'\beta'},$$

so

$$|\alpha|^2 \approx |\beta|^2 \approx 1 - |\lambda|^2 \approx 1 - |\mu|^2.$$

The quantities

$$|\alpha|^2 = k_a r^a / t_b r^b, \quad |\lambda|^2 = k_a t^a / r_b t^b, \text{ etc.}$$

can be expressed directly in terms of the scattering angle. Explicitly we have (taking the momentum conservation relation to hold)

$$|\alpha| = |\beta| = C, \quad |\lambda| = |\mu| = S$$

provided k^a and s^a are incoming (with $k^a \rightarrow t^a, s^a \rightarrow r^a$), or else if t^a and r^a are incoming ($t^a \rightarrow k^a, r^a \rightarrow s^a$), where we have set

$$C = \cos \frac{1}{2} \theta, \quad S = \sin \frac{1}{2} \theta,$$

the scattering angle θ being measured in the centre-of-mass frame.

Taking account of the modifications that are required when *other* pairs of states are the incoming ones, we have:

$$|\alpha| = |\beta| = 1/C, \quad |\lambda| = |\mu| = S/C$$

if k^a and r^a are incoming ($k^a \rightarrow t^a, r^a \rightarrow s^a$) or else s^a and t^a are incoming ($s^a \rightarrow r^a, t^a \rightarrow k^a$); or

$$|\alpha| = |\beta| = C/S, \quad |\lambda| = |\mu| = 1/S$$

if k^a and t^a are incoming ($k^a \rightarrow s^a, t^a \rightarrow r^a$), or else r^a and s^a are incoming ($r^a \rightarrow t^a, s^a \rightarrow k^a$). (Such manifestations of crossing symmetry must arise automatically in this theory owing to the analyticity of the operations involved.)

Let us consider the high energy limit of Möller scattering (fig. 11). We represent time as proceeding up the page in our diagrams. Thus we have

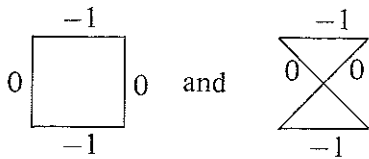
(4.28) 

when the helicities of the two incoming (massless) electrons are opposite and

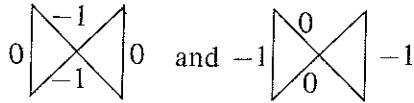

if the helicities are the same. Because of Fermi-Dirac statistics applying when the helicities are the same we must combine these last two amplitudes coherently, i.e. subtract them from one another – or else add them (since a sign uncertainty arises here owing to the lack of a definite rule, as yet, for choosing the contour orientations) – before taking the squares of their moduli. Summing (incoherently) over the different helicities we get, for unpolarized electrons

$$\left| \begin{array}{c} -1 \\ \square \\ -1 \end{array} \right|^2 + \left| \begin{array}{c} -1 \\ \square \\ -1 \end{array} \right|^2 + \left| \begin{array}{c} -1 \\ \square \\ -1 \end{array} \right|^2 + \left| \begin{array}{c} 0 \\ \square \\ 0 \end{array} \right|^2$$

$$= \left\{ \left(\frac{C^2}{S^2} \right)^2 + \left(\frac{S^2}{C^2} \right)^2 + \left(\frac{1}{S^2} + \frac{1}{C^2} \right)^2 \right\} \delta$$

for the differential cross-section (ignoring possible overall factors and taking the plus sign so as to agree with the correct answer [48]!).

The calculation for Compton scattering (or equivalently, by crossing symmetry, for pair annihilation) is similar, where we use

$$\begin{array}{c} 0 \quad -1 \\ \square \\ -1 \quad 0 \end{array} = \mu^{-1} (\alpha\beta - \lambda\mu)^{-1} \delta.$$

The comparison for pair annihilation is as follows:

$$\left| \begin{array}{c} -1 \\ \square \\ 0 \end{array} \right|^2 + \left| \begin{array}{c} -1 \\ \square \\ 0 \end{array} \right|^2 = \left\{ \left(\frac{S}{C} \right)^2 + \left(\frac{C}{S} \right)^2 \right\} \delta$$

in agreement (ignoring an overall factor) with the standard result [48].

5. Further developments

In this section some of the later developments in twistor theory, which have evolved since the lecture course in 1970, will be outlined. These developments are still in progress and it will not be appropriate to go into them in full detail, but the main ideas will be discussed.

5.1. Asymptotic twistors

Recall the definition of a null global twistor Z^α in curved space-time, given in section 3.2, as a null geodesic Z along which a spinor π_A is defined, the flagpole direction of π_A being everywhere tangent to the null geodesic and π_A being propagated parallelly along it. The basic difficulty with this is that we have too little structure; all we obtain is a symplectic structure, and non-null twistors are not even defined. There is no complex structure, essential if contour integrals are to have a meaning; and the basic ingredient of the contour integrals we have been considering, namely the twistor scalar product, is also missing. However, if our intention is to employ such concepts in the construction of an S -matrix theory applicable to curved space-times, the situation is considerably more encouraging. For then we can reasonably restrict attention to space-times which are, in the appropriate sense, asymptotically flat. We shall assume, also, that the Einstein vacuum or Einstein-Maxwell equations (without cosmological term) hold at large distances. Then each null geodesic starts out from a region, remote from massive sources, where the space-time is flat enough that additional twistor structure of the type required can be assigned — and likewise it ends up in such a region. It turns out that the normal assumptions of asymptotic flatness are just sufficient that non-null twistors, a complex structure, and a form of scalar product can all be defined. However, enough residual space-time curvature is still present at infinity to give a twistor space structure essentially *different* from that of Minkowski space-time. In effect, the twistor space becomes *curved* (as a Kähler manifold).

To carry out a detailed discussion, we shall require the picture of conformal infinity appropriate to an asymptotically flat space-time M . For details, see [2, 4, 41]. We have already considered compactified Minkowski space in section 1.1. The essential new feature in the case of an asymptotically flat space is that past null infinity and future null infinity cannot be usefully identified with each other. By introducing a convenient conformal factor which falls off suitably towards null infinity, we obtain a new metric $\hat{g}_{ab} = \Omega^2 g_{ab}$ which remains finite and smooth along the two adjoined bounding null hypersurfaces I^- , representing past null infinity, and I^+ , representing future null infinity. The picture is that of fig. 1 but without the identification.

In a scattering problem, the data specifying the in-states (assumed zero rest-mass) would be given on I^- and those specifying the out-states on I^+ . Each point of I^- is the vertex of a light cone whose generators, namely the null geodesics through that point, would describe a null hypersurface in M which is asymptotically plane in the past. This hypersurface could therefore be thought of as a constant phase hypersurface of an incoming asymptotic plane wave. (Ignore dispersion effects.) Similarly, each point of I^+ may be associated with a constant phase hypersurface of an outgoing asymptotic plane wave.

Every null geodesic in M acquires a past end-point on I^- and a future end-point on I^+ (taking "asymptotic simplicity" [2, 4], as a necessary condition for asymptotic flatness); also there is a null geodesic *on* I^\pm through each point on I^\pm — since I^\pm , being null hypersurfaces, are generated by null geodesics. The different points of one generator of I^- represent the different constant

phase hy
ator of I
generato
tor of I^+
rection.
ferent (i.
of I^- wil
for the p
rections

Not o
situation
the asymp
 Ψ_{ABCD} r
does not
fional ra
tors of I
squared
The qual
of (Bond

We sh
pending
 I^+ , but v
retarded
 I^+ , howe
think th
twistor t

(cf. (3.8)
hence of
lead to a
since the
spinor (i
if $(\omega^A, \pi$
ent route

We mi
have a sp

where a

¹Strictly s
However,
to.

phase hypersurfaces of the *same* incoming asymptotic plane wave; similarly, the points of a generator of I^+ represent the various phase hypersurfaces of one outgoing asymptotic plane wave. Each generator of I^- can be shown to be naturally associated with a corresponding "opposite" generator of I^+ . That is, each incoming null direction defines a unique "undeflected" outgoing null direction. For a *given* null geodesic in M , the incoming and outgoing directions will in general be different (i.e. "deflection" occurs). There appears to be no natural association of an individual *point* of I^- with some uniquely corresponding *point* of I^+ . This means that we have no natural meaning for the phase shift between ingoing and outgoing asymptotically plane waves even when their directions agree.

Not only is the relation between I^- and I^+ different, for an asymptotically flat space, from the situation for Minkowski space, but the structure of each of I^- and I^+ contains information about the asymptotic gravitational field. It turns out that the Weyl tensor C_{abcd} or equivalently the spinor³⁰ Ψ_{ABCD} must vanish on I^\pm . But the quantity $K_{abcd} = \Omega^{-1} C_{abcd}$ (equivalently $\phi_{ABCD} = \Omega^{-1} \Psi_{ABCD}$) does not (cf. (1.27)) in general. The component $\Psi_4 := \phi_{ABCD} t^A t^B t^C t^D$ in fact measures the gravitational radiation field, incoming if on I^- and outgoing if on I^+ , where t^A points along the generators of I^\pm . Ψ_4^0 is the derivative along generators of I^\pm of the Bondi-Sachs news function N , whose squared modulus $N\bar{N}$ may be taken to represent the energy-flux of gravitational radiation across I^\pm . The quantity N governs the rate of change, along the generators of I^\pm , of the asymptotic shear σ^0 of (Bondi-type) systems of advanced or retarded time hypersurfaces.

We shall next define the space \mathcal{C} of asymptotic twistors. In fact there are two such spaces depending upon whether we use I^- or I^+ on which to define things. For definiteness, let us choose I^+ , but we must bear in mind that a parallel discussion in terms of I^- can also be given. (For a *retarded* gravitational field we would expect to obtain a less interesting structure for I^- than for I^+ , however.) Consider local twistors $(\omega^A, \pi_{A'})$ (cf. section 3.1) defined at points of I^+ . We might think that since the conformal (Weyl) curvature vanishes at every point of I^+ , we could use local twistor transport, i.e.

$$t^b \nabla_b \omega^A = -i t^{AB'} \pi_{B'}, \quad t^b \nabla_b \pi_{A'} = -i P_{BCB'} t^{BB'} \omega^C \tag{5.1}$$

(cf. (3.8)), to carry the local twistor $(\omega^A, \pi_{A'})$ along a curve on I^+ with tangent vector t^b and hence obtain an *integrable* equivalence between local twistors at different points on I^+ . This would lead to a single twistor space for the whole of I^+ . Unfortunately, things are not as simple as this since the commutator of local twistor derivatives involves the *derivative* of the Weyl conformal spinor (in fact the quantity $\nabla_{A'}^A \Psi_{ABCD}$, cf. (3.11)) and this does *not* vanish on I^+ , in general. Thus, if $(\omega^A, \pi_{A'})$ is carried by local twistor transport from one point of I^+ to another over two different routes each lying on I^+ , then we must expect that in general unequal results will be obtained.

We must therefore proceed somewhat differently. Let us consider local twistors on I^+ which have a spinor representation of the form

$$(\xi t^A, \pi_{A'}) \tag{5.2}$$

where a particular selection of the spinor t^A at each point (with flagpole pointing along the

³⁰Strictly speaking, these should be denoted \hat{C}_{abcd} and $\hat{\Psi}_{ABCD}$, respectively, since they refer to the metric \hat{g}_{ab} and not g_{ab} . However, we shall, for convenience, drop all "hats" in this section, it being assumed that the metric \hat{g}_{ab} is being always referred to.

generator of I^+ through the point) is made. We can use local twistor transport along generators of I^+ to equate local twistors of this form at different points on the same generator. (The form (5.2) is preserved by (5.1), if we propagate along generators ($t^a = t^A t^{A'}$); also no problems from non-integrability can arise since the generators are one-dimensional simply-connected lines.) Thus, associated with every generator of I^+ we have a 3-complex-dimensional vector space, parameterized at any one point of the generator by ξ and the two components of $\pi_{A'}$. The generators of I^+ themselves can be labelled by one further complex parameter ζ . Thus we can assemble a 4-complex-dimensional manifold of quantities of this kind. This is the "blown-up" manifold of (future) asymptotic twistors.

We shall give some structure to this manifold shortly. For the moment, let us explain how this picture arises, a little more fully. Consider an ordinary global null twistor Z^α (cf. (3.2)) in M . The null geodesic Z which it defines intersects I^+ at a single point P , say. We have $\pi_{A'}$, parallelly propagated along Z with respect to both the physical and conformally rescaled metrics (as follows from (1.19a) since $\bar{\pi}^A \pi^{A'} \nabla_{AA'}$ defines propagation along Z). Thus we can define $\pi_{A'}$ at P as well as at finite points of Z . Furthermore, knowledge of the point P on I^+ and of $\pi_{A'}$ at P will be sufficient to determine the twistor Z^α . Let us label Z^α by the local twistor $(0, \pi_{A'})$ at P .

This is of the form (5.2) at P , so local twistor transport along the generator γ of I^+ through P , to a point Q , yields another local twistor of the form $(\xi t^A, \pi_{A'})$. Knowing this local twistor at Q we can locate P simply by finding the point at which ξ is reduced to zero. The $\pi_{A'}$ at that point enables us to locate the global twistor Z . Of course not every $(\xi t^A, \pi_{A'})$ at Q yields a point P at which ξ is reduced to zero, since ξ is complex and we have one real dimension of points on γ . The condition that P does exist, assuming that $\pi_{A'}$ is not proportional to $t_{A'}$, is that the local twistor $(\xi t^A, \pi_{A'})$ be null, i.e.

$$\text{Re}(\bar{\xi} \pi_{1'}) = 0 \tag{5.3}$$

where $\pi_{1'} = \pi_{A'} t^{A'}$. Note that $Z^\alpha \bar{Z}_\alpha$ is preserved under local twistor transport.

If u is a parameter associated with the tangent vector $t^A t^{A'}$ to γ (i.e. $\nabla_{11'} := t^A t^{A'} \nabla_{AA'} = d/du$ when applied to scalar functions on γ) and if we choose t^A to be parallelly propagated along γ (i.e. $\nabla_{11'} t^B = 0$) then (5.1) with $t^a = t^A t^{A'}$ gives

$$d\xi/du = -i\pi_{1'}. \tag{5.4}$$

It is convenient to choose the conformal factor Ω so that the divergence of the generators of I^+ vanishes. The shear of I^+ necessarily also vanishes [4]. The generators of I^+ then become parallel to one another, in the sense that every cross-section of I^+ (a spacelike 2-surface) has the same metric (induced by \hat{g}_{ab}) as every other. Under these circumstances it can be shown [4, 42] that:

$$P_{111'A'} := P_{BAB'A'} t^B t^A t^{B'} = 0. \tag{5.5}$$

Then, from (5.1) we obtain

$$\nabla_{11'} \pi_{A'} = -iP_{111'A'} \xi = 0 \tag{5.6}$$

and, in particular,

$$d\pi_{1'}/du = 0. \tag{5.7}$$

From th
for the l
this form
as inters
 I^+ This
Now
point of

where ξ
case of M
null twis
global tv
 $\pm \infty$). Th
we could
ticular, s
these ha

Our desc
be made
be carri
How the
achieving
further s
of I^+ are
in which

are form

are retai
plied to
equivalen
The resu
classes d
are the (
the quar

There is 1
der confc

From this and (5.4) we obtain the formula,

$$u(P) = u(Q) - i\xi/\pi_{A'}$$
(5.8)

for the location of P in terms of that of Q and the value $(\xi t^A, \pi_{A'})$ at Q. If (5.3) is *not* satisfied, then this formula would give us a *complex* value of u on γ . Thus we may think of the non-null twistors as intersecting I^+ in points with complex u coordinates. That is, they intersect the "complexified" I^+ . This point of view will be developed further shortly.

Now consider what happens when $\pi_{A'}$ is proportional³¹ to $t_{A'}$, i.e. when $\pi_{A'} = 0$. We have, at each point of γ , a local twistor of the form

$$(\xi t^A, \eta t_{A'}),$$
(5.9)

where ξ and η are constant all along γ . It is worth examining the meaning of such a quantity in the case of Minkowski space. Here I^+ may be viewed as a light cone with a vertex, namely I . A local null twistor $(\xi t^A, \pi_{A'})$ at Q, which approaches the form $(\xi t^A, \eta t_{A'})$ at Q in the limit, represents a global twistor Z^α where $P = Z \cap \gamma$ approaches I in the limit (see (5.8): the value $u(P)$ approaches $\pm \infty$). Thus, $(\xi t^A, \eta t_{A'})$ at Q represents some null twistor Z^α whose null line passes through I . But we could represent this same null twistor Z^α equally well using any *other* generator of I^+ . In particular, since Z itself now becomes a generator, we may use local twistors along Z to describe Z^α , these having the particular form

$$(0, \eta t_{A'}).$$
(5.10)

Our description of Minkowski space twistors in terms of I^+ thus entails a further identification to be made whenever the local twistors we use take the form (5.9). Such an identification *can*, in fact, be carried out for asymptotically flat space-times (although it may not always be desirable to do so). How then do we carry out such an identification in general? There are various equivalent ways of achieving this, but they all amount to the following. Specialize the choice of a conformal factor further so that the generators of I^+ are not only parallel but so that in addition, the cross-sections of I^+ are all spheres. (This can be done [41].) Then use a form of *modified* local twistor transport in which the parts of $P_{ABA'B'}$ of the form

$$P_{11A'B'} \quad \text{and} \quad P_{AB1'1'}$$
(5.11)

are formally put equal to zero while those of the form

$$P_{1A1'A'}, \quad P_{A11'A'}, \quad P_{1AA'1'}, \quad P_{A1A'1'}$$
(5.12)

are retained. (There is no inconsistency between these requirements because of (5.5).) When applied to local twistors of the form (5.9) this transport turns out to be integrable, so the required equivalence relation between quantities (5.9) at the various points of I^+ may thereby be achieved. The resulting equivalence classes are called *asymptotic twistors entirely on I^+* . The equivalence classes defined earlier for local twistors on I^+ of the form (5.2) which are *not* of the form (5.9), are the (*future*) *asymptotic twistors not entirely on I^+* . The (*future*) *asymptotic twistors* are simply the quantities of one or other of these kinds.

³¹There is no invariant significance in the further specialization to $\pi_{A'} = 0$ since, assuming $\xi \neq 0$, this condition is not invariant under conformal rescaling, cf. (3.1) even when the rescaling factor is chosen constant along generators of I^+ .

The above procedure may seem to the reader to be artificial. However, this is not really so. We may think of it in another way. We may assume that the gravitational radiation emitted (or transmitted) is of an effectively finite duration, that is to say that it falls off appropriately to zero when the absolute value of u is large. Now the quantities (5.11) describe, in effect, the Bondi–Sachs news function N (and \bar{N}) and so must be expected to approach zero for large $|u|$. The quantities (5.12) are, on the other hand, constant along the generators of I^+ (and are, in fact, constant multiples of $\iota_A \iota_{A'}$, over the whole of I^+). In effect, we may think of the modified local twistor transport as being the limit as $|u| \rightarrow \infty$ of ordinary local twistor transport on I^+ . In the limit, this local twistor transport becomes integrable for the quantities (5.9).

It is worth remarking, also, that there is a limiting case of our above construction in which things can be seen a little more simply. This is to make a choice of Ω in which the cross-sections of I^+ are *planes* and to send one of the generators of I^+ effectively “back to infinity”. With this choice of Ω it is possible to scale ι^A so that it is constant over the whole of I^+ . In fact, we can arrange

$$\nabla_{AA'} \iota^B = 0. \quad (5.13)$$

We also have

$$P_{11A'B'} = N \iota_A \iota_{B'} \quad (5.14)$$

with this choice of Ω , and the quantities (5.12) all vanish. Such a choice of Ω and ι^A is a very convenient one for calculations on I^+ (cf. [42, 43]). Recall also that $\Psi_{ABCD} = 0$ on I^+ , so very few curvature components survive on I^+ , the complex quantity N being the most significant one. To construct our equivalence relation between local twistors of the form (5.9), we can proceed by making such a choice of Ω , so that at one point $Q \in I^+$ a given local twistor is reduced to the form $(\xi \iota^A, 0)$. There is still just enough freedom in Ω for this, provided that $\xi \neq 0$. Then the other local twistors equivalent to this one are the ones also of this form $(\xi \iota^A, 0)$, where ξ is *constant* throughout I^+ . The null line represented by the resulting asymptotic twistor is then the generator of I^+ which is sent back to infinity with this choice of Ω .

In the case of Minkowski space, the asymptotic twistors which are entirely on I^+ are those (apart from the zero twistor) whose representations in the C-picture are as points of the line I. If we do not carry out the identification, over the *whole* of I^+ , between local twistors of the form (5.9), but use only the previous identification given by local twistor transport along generators (which applied also to (5.2)), then we obtain a *blown-up asymptotic twistor* entirely on I^+ . This terminology comes from the name of a procedure sometimes applied in algebraic geometry in which a certain set of points may, in an algebraic fashion, be replaced by another set of higher dimensionality. In this case, I is “blown-up” to become a quadric surface, each point of which represents not only a point of I but also a plane through I.

Asymptotic twistor space may be viewed as a *fibre bundle* of, roughly speaking, spin-space over spin-space (actually over the dual complex conjugate spin-space). This generalizes the situation in Minkowski space-time, where, referred to an ordinary Minkowski metric and origin, a twistor Z^α may be represented as $(\omega^A, \pi_{A'})$. The base space is the space of $\pi_{A'}$ (namely the dual conjugate spin-space). The fibre over each fixed $\pi_{A'}$ is the space of ω^A (spin-space). This bundle structure is Poincaré (but not conformally) invariant. There is no Poincaré invariant cross-section, but the (Poincaré invariant) projection to the base is given by

$$(\omega^A, \pi_{A'}) \mapsto \pi_{A'} \tag{5.15}$$

There is just one Poincaré invariant injection of spin-space into the bundle as a fibre, namely the fibre over $\pi_{A'} = 0$:

$$\omega^A \mapsto (\omega^A, 0) \tag{5.16}$$

This gives us a short exact sequence

$$0 \rightarrow S^A \rightarrow T^\alpha \rightarrow S_{A'} \rightarrow 0 \tag{5.17}$$

where the letters S and T represent spin-space and twistor-space, respectively, of the type indicated by the indices. Taking the dual spaces we get

$$0 \leftarrow S_A \leftarrow T_\alpha \leftarrow S^{A'} \leftarrow 0 \tag{5.18}$$

This exact sequence is actually also the complex conjugate of (5.17). All this structure persists³² also for asymptotic twistors. To see this, we must identify the required spin-space — *asymptotic spin-space* — for an asymptotically flat space-time. This may be done in terms of a double covering of the cotangent bundle of the space of generators of I^+ . Equivalent, but more convenient for our present purposes, is to use the space of asymptotic twistors which are entirely on I^+ . Since we have an equivalence relation over the whole of I^+ , we can add two such asymptotic twistors simply by adding the corresponding local twistors at some given point Q of I^+ . The result is independent of Q . We can likewise multiply such asymptotic twistors by scalars and derive a two-complex-dimensional vector space structure. The two complex quantities ξ, η serve as components, where (ξ^1, η^1) is the local twistor representation at Q . We can define the required (skew-symmetrical) spinor scalar product between (ξ^1, η^1) and (ξ^2, η^2) to be

$$i\xi^1\eta^2 - i\eta^1\xi^2 \tag{5.19}$$

provided t^A is scaled so that

$$\nabla_{AA'}\Omega = -t_A t_{A'} \tag{5.20}$$

on I^+ . (Eq. (5.20) is in fact consistent with our other assumptions.) The definition (5.19) turns out to be independent of Q and of the choice of Ω (because the scaling (5.20) implies that $t^A t_{A'}$ is independent of Ω). This invariant skew scalar product completes the definition of the structure of asymptotic spin-space. The definition does in fact agree with the ordinary spin-space structure for Minkowski space.

Since we have defined asymptotic spin-space as a subspace of asymptotic twistor space, the injection (5.16) is established (as an inclusion) for asymptotically flat space-time. Now examine the projection (5.15). This can be re-expressed

$$(\omega^A, \pi_{A'}) \mapsto (0, \pi^{A'}) \tag{5.21}$$

where the expression on the right refers to a twistor of valence $\begin{bmatrix} 0 \\ 1 \end{bmatrix}$ and is obtained by

³²Except that the interpretation of the complex conjugate of asymptotic twistor space as being also its dual space may not be valid.

$$Z^\alpha \mapsto I_{\alpha\beta} Z^\beta. \tag{5.22}$$

Reverting, now, to the description of asymptotic twistors in terms of local twistors on I^+ , we can derive the form (at any Q)

$$I_{\alpha\beta} \leftrightarrow \begin{pmatrix} 0 & -it_A t^{B'} \\ it^{A'} t_B & 0 \end{pmatrix} \tag{5.23}$$

for the infinity twistor. Applying (5.23) to (5.22), we obtain, with respect to Q , the version of (5.21) which applies to asymptotic twistors:

$$(\xi t^A, \pi_{A'}) \mapsto (-i\pi_{1'} t_A, 0) \tag{5.24}$$

(Having the same form as the complex conjugate of (5.10), the right-hand side of (5.24) describes an asymptotic twistor of valence $[\begin{smallmatrix} 0 \\ 1 \end{smallmatrix}]$ as required.) The fibre above the asymptotic spinor given by the right-hand side of (5.24) is the kernel of (5.24), that is, the space of $(\xi t^A, \pi_{A'})$ for $\pi_{1'} = 0$.

We can use ξ and $\pi_{0'}$, at Q , as components for this two-complex-dimensional vector space. There is no invariant skew-symmetrical scalar product. Instead, the group of the fibre may be taken to be simply $L(2, \mathbb{C})$.

We can add two asymptotic twistors if they lie in the same fibre, but there is no clear way to do so if they are associated with different generators of I^+ . Any asymptotic twistor can be multiplied by a scalar.

Let us now consider how the complex structure for the space of asymptotic twistors (or of blown-up asymptotic twistors) is to be defined. The clearest way to do this seems to be to give an interpretation of asymptotic twistors in terms of the *complexified* I^+ . This is not the most satisfactory procedure mathematically, since in order that this complexification be possible at all, it is necessary that the structure of I^+ be *analytic*. This entails that the outgoing gravitational radiation must be analytic, so gravitational pulse waves or sandwich waves (e.g. Bondi's "time-bomb") must be excluded. It would be more satisfactory to define all the required structure in terms of the *real* I^+ – and presumably, it will eventually become possible to do this – but in any case the loss of generality involved in our approach may be small, since any non-analytic behaviour can be approximated arbitrarily closely by means of an analytic I^+ .

Let us use coordinates u, ζ for I^+ , where u is a real parameter define along the generators of I^+ as described earlier (so u is actually a retarded time parameter which is constant along each generator and which labels the generators in the standard way, i.e. $\zeta = \exp(-i\varphi) \cot \frac{1}{2}\theta$, where θ and φ are ordinary spherical polar coordinates for the spheres of cross-section of I^+). To complexify I^+ , we allow u to become a complex parameter v and we "free" ζ from its complex conjugate $\bar{\zeta}$. That is to say, given any quantity, defined on I^+ as an analytic function $\chi(u, \zeta, \bar{\zeta})$, we extend this to the complexified I^+ – denoted $\mathbb{C}I^+$ – by the unique (locally at least) holomorphic function of three independent complex variables $v, \zeta, \tilde{\zeta}$, (still written $\chi(v, \zeta, \tilde{\zeta})$) whose value is given by $\chi(u, \zeta, \bar{\zeta})$ when $v = u$ is real and $\tilde{\zeta} = \bar{\zeta}$.

Since the range of ζ is really to be thought of as the Riemann sphere S^2 ($\zeta = \infty$ being allowed), this gives the topology of $\mathbb{C}I^+$ as $\mathbb{R}^2 \times S^2 \times S^2$. (The parameter v ranges over $\mathbb{C} \cong \mathbb{R}^2$ and ζ and $\tilde{\zeta}$ each independently range over S^2 .) This picture is not really quite accurate, however. This is because certain quantities defining the structure of I^+ will become *singular* if defined too far away from the real section I^+ of $\mathbb{C}I^+$. This will apply, in particular, to the gravitational radiation field

ψ_A . (Func
ended to
 $\mathbb{R}^2 \times S^2 \times$
Let us c
provided π
singular fo

Now, start
(5.25) we
(complex)

by (5.1)).
global twis
plexified \mathbb{P}
(5.26). In
the line Z)
plane (assu
 $I^+ = \mathbb{C}Z \cap$

since these
geodesic o

by (5.1))
obtain the
invariant-

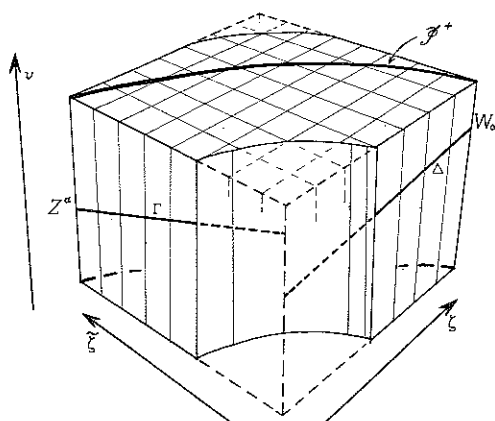

Fig. 40.

Ψ_A . (Functions, such as $(1 + u^2)^{-1}$, which are well-behaved for real u become singular when extended to complex values.) Thus, the manifold $\mathbb{C}I^+$ consists just of some neighbourhood of I^+ in $\mathbb{R}^2 \times S^2 \times S^2$ (see fig. 40).

Let us consider local twistors on $\mathbb{C}I^+$ of the form $(\xi t^A, \pi_{A'})$ at $Q \in I^+$. Since v is complex we can, provided $\pi_{1'} \neq 0$, use (5.8) to find a point P on the generator $\mathbb{C}\gamma$ of $\mathbb{C}I^+$ (or of $\mathbb{R}^2 \times S^2 \times S^2$, if P is singular for $\mathbb{C}I^+$) through Q , at which local twistor transport reduces ξ to zero to give

$$(0, \pi_{A'}). \tag{5.25}$$

Now, starting from any point on $\mathbb{C}I^+$, or on $\mathbb{C}M$, at which we have a local twistor of the form (5.25) we can, by means of local twistor transport, maintain the form (5.25) by moving in any (complex) direction of the type

$$t^a = \tau^A \pi^{A'} \tag{5.26}$$

(by (5.1)). In flat (or conformally flat) space, local twistor transport is integrable and defines a global twistor Z^α (section 3.1). The points at which the form (5.25) holds then constitute a complexified plane (a four-real-dimensional subset of $\mathbb{C}M$) whose tangent vectors are all of the type (5.26). In the case of a null twistor Z^α , such a plane contains one real null line of points (namely the line Z); in the general case, when $Z^\alpha \bar{Z}_\alpha \neq 0$, no point on the plane is real. This complexified plane (assuming that it is not contained in $\mathbb{C}I^+$) will intersect $\mathbb{C}I^+$ in a complexified line $\Gamma = \mathbb{C}Z \cap \mathbb{C}I^+$, the tangents to Γ being proportional to

$$t^a = \iota^A \pi^{A'} \tag{5.27}$$

since these are the complex vectors of the type (5.26) which are tangent to $\mathbb{C}I^+$. In fact Γ is a null geodesic on $\mathbb{C}I^+$, which follows from the fact that

$$\iota^B \pi^{B'} \nabla_{BB'} \pi_{A'} = 0 \tag{5.28}$$

(by (5.1)) together with (5.13). (If we do not choose to scale things so that (5.13) holds, then we obtain that $t^b \nabla_b t^a$ is proportional to t^a .) Recall that the concept of a null geodesic is conformally invariant—this applies also to complex null geodesics.

Reverting to the general case, when M is asymptotically flat, we can likewise define the null geodesic Γ through $P \in \mathbb{C}I^+$ in the direction given by $\iota^A \pi^{A'}$, and associate the local twistor $(0, \pi_{A'})$ with each point of Γ , $(0, \pi_{A'})$ being carried along Γ by local twistor transport. Now the surfaces $\zeta = \text{const.}$ on $\mathbb{C}I^+$ have tangent vectors of the type $\iota^A \kappa^{A'}$, as in (5.27); the surfaces $\tilde{\zeta} = \text{const.}$ have tangent vectors of the type $\tau^A \iota^{A'}$. Thus, Γ lies entirely in one $\zeta = \text{const.}$ surface. Each point of Γ is labelled by a different value of $\tilde{\zeta}$ (assuming $\pi_{A'}$ is not proportional to $\iota_{A'}$). The value of v at $\tilde{\zeta} = \tilde{\zeta}$, together with $\pi_{A'}$ at that point serves to define Γ . Conversely, Γ , together with the scaling afforded by the choice of tangent vector $\iota^A \pi^{A'}$, defines v, ζ and $\pi_{A'}$, and so corresponds uniquely to an asymptotic twistor not entirely on I^+ . There are also null geodesics on $\mathbb{C}I^+$ lying on $\tilde{\zeta} = \text{const.}$ planes. These have tangent vectors of the type $\mu^A \iota^{A'}$ and may, in a similar way, be associated with dual asymptotic twistors not entirely on I^+ . All null geodesics on $\mathbb{C}I^+$ have one or other of these forms – except that there are some, namely the generators of $\mathbb{C}I^+$, which have both forms simultaneously. These generators are associated with blown-up asymptotic twistors (entirely on I^+). The asymptotic twistors entirely on I^+ which are not blown up must be associated with whole $\tilde{\zeta} = \text{constant}$ planes; the dual asymptotic twistors of the same type are associated with $\zeta = \text{const.}$ planes.

This description of asymptotic twistors is given on $\mathbb{C}I^+$ completely without reference to the notion of complex conjugate. It follows that the manifold of these asymptotic twistors has a naturally defined complex structure. This is the complex structure that we assign to asymptotic twistor space and which makes this space into a complex manifold. There is a snag, however. This is that for some asymptotic twistors, the point P that we defined to start with to obtain the form (5.25) may not actually lie in $\mathbb{C}I^+$, but in the region excluded from $\mathbb{R}^2 \times S^2 \times S^2$ because $\mathbb{C}I^+$ becomes singular there. It seems that in general the complex structure for asymptotic twistor space must break down in such regions. However, this only occurs outside some neighbourhood of the space of null asymptotic twistors. But it does have the effect that although the space of asymptotic twistors is compact, the subspace on which a complex structure is defined is non-compact. (It seems rather probable that this non-compact complex manifold can be extended to become compact again, but this is not certain. If this can be done, then it can be done uniquely and a well-defined symmetry group isomorphic to the complex Poincaré group or complex conformal group will arise. This is presently under investigation.)

To obtain the geometric meaning of the complex structure of asymptotic twistor space, let us consider the asymptotic analogue of the Kerr theorem³³. The asymptotic C-picture consists of equivalence classes of proportional asymptotic twistors. Each point of $\mathbb{C} - \mathbb{I}$ represents a null geodesic on $\mathbb{C}I^+$ (in a $\zeta = \text{const.}$ plane but which is not a generator). A complex analytic surface in \mathbb{C} defines a complex analytic congruence of such null geodesics. Those which meet I^+ (represented by points on \mathbb{N}) define a field on $\pi_{A'}$'s (up to proportionality) on I^+ . Now the equation (5.28) must be satisfied – or, if we are not concerned with the scaling of $\pi_{A'}$, but merely its flag-pole direction – the equation

$$\iota^B \pi^{B'} \pi^{A'} \nabla_{BB'} \pi_{A'} = 0. \tag{5.29}$$

³³We are deeply indebted to E.T. Newman for informing us of his work with Aronson, Lind and Messmer [44] on asymptotically shear-free congruences. It was their asymptotic version of the Kerr theorem which provided the initial inspiration for the theory of asymptotic twistors described here. Their ϕ -functions correspond to complex-analytic functions on $\mathbb{C}I^+$ whose level surfaces are ruled by null geodesics in $\zeta = \text{const.}$

If we define which intersects the equator

$$\pi^B$$

at I^+ . This is at $(\sigma^0 = 0)$ at I^+

Finally, let us consider a twistor and its intersection with the null $\mathbb{C}I^+$. There is a singularity at $\zeta = \tilde{\zeta}$, $\tilde{\zeta} = \tilde{\zeta}$ (fig. 40), the singularities along this geodesic are the scalar product with Δ

When W_β is defined, the definition of complexification of a scalar function on a Kähler manifold and of complexification in terms of $\Psi_1^0, \Psi_3^0, \text{Im } \Psi_3^0$

$$i\Psi$$

and (in the case of these calculations)

5.2. Scattering

In section 5.1 we saw that the equations of null twistor space are quantum problems. In this section we shall see how they are achieved. In this section we shall see how they are effected by the present theory. The twistor theory is to be correct and to be elusive. The twistor theory is to be correct and to be elusive.

If we define $\pi_{A'}$ away from I^+ by means of parallel propagation along the null geodesics (λ) in M which intersect I^+ in the directions defined by the $\pi_{A'}$'s (i.e. $\bar{\pi}^B \pi^{B'} \nabla_{BB'} \pi_{A'} = 0$) then we arrive at the equation

$$\pi^{B'} \pi^{A'} \nabla_{BB'} \pi_{A'} = 0$$

at I^+ . This will be recognized [9] as the condition that the congruence (λ) should be shear-free ($\sigma^0 = 0$) at I^+ i.e. that it should be *asymptotically shear-free*.

Finally, let us define the scalar product on asymptotic twistor space. Let Z^α be an asymptotic twistor and W_β a dual asymptotic twistor, neither of which lies entirely on I^+ . Let Z^α be associated with the null geodesic Γ on $\xi = \xi_1$ on $\mathbb{C}I^+$ and W_β associated with the null geodesic Δ on $\tilde{\xi} = \tilde{\xi}_2$ on $\mathbb{C}I^+$. There will be a unique generator of $\mathbb{C}I^+$ which meets both of Γ and Δ , namely that given by $\xi = \xi_1, \tilde{\xi} = \tilde{\xi}_2$, provided that the intersection points do not lie in the singular region. If they do (see fig. 40), the scalar product has become singular, so suppose they do not. Then (providing also that the singular region of $\mathbb{C}I^+$ does not disconnect the two points) we can use local twistor transport along this generator to carry the local twistor defining W_β to the intersection with Γ and perform the scalar product at that point (or else we can carry the local twistor defining Z^α to the intersection with Δ — it makes no difference to the answer).

When $W_\beta = \bar{Z}_\beta$, this gives us the definition of $Z^\alpha \bar{Z}_\alpha$ which comes directly from the local twistor definition of $Z^\alpha \bar{Z}_\alpha$ implicit in (5.3). (In fact, the above scalar product of Z^α with W_β is simply the "complexification" of $Z^\alpha \bar{Z}_\alpha$ where \bar{Z}_α is allowed to become "freed" from Z^α .) Having a real-valued scalar function defined on asymptotic twistor space as well as a complex structure, we have also a Kähler manifold structure (of signature $(++--)$ [45]. This leads to a concept of covariant derivative and of curvature for asymptotic twistor space. This Kähler curvature can be computed explicitly in terms of quantities relating to the asymptotic space-time curvature. These quantities are $\Psi_4^0, \Psi_3^0, \text{Im}(\Psi_2^0)$ cf. [9], these being the components of

$$i\Psi_{AB11} \iota_A \iota_{B'} - i \iota_A \iota_B \bar{\Psi}_{A'B'1'1'}$$

and (in the case of non-null twistors) certain integrals of such quantities up the generators of I^+ . These calculations are too involved to be usefully described here.

5.2. Scattering off a fixed source

In section 3.2 we considered the classical scattering of zero rest-mass particles (described in terms of null twistors) by a fixed gravitational or electromagnetic wave. Employing the Hamiltonian equations which arose we attempted to find the correct twistor description of the corresponding quantum processes. In the electromagnetic case this was successful only after the (unmotivated) introduction of an extra line into the diagrams; in the gravitational case success has not yet been achieved. In this section we briefly consider a variation on this programme in which the scattering is effected by the field of a fixed source rather than by a free wave. The contour integrals which arise present some distinctly new features — and are in several respects more satisfactory than the ones arising in the case of the free waves. The results obtained for the classical scattering turn out to be correct, but a valid procedure for obtaining the correct quantum scatterings at first proved to be elusive. This narrowed down the area in which new developments in the theory were required. The twistor description of the electromagnetic and gravitational potentials given in section 5.3 in fact forms the basis of these new developments.

(5.29)

on asymptotically
ion for the theory
ose level surfaces

In order to describe the electromagnetic or (linearized) gravitational field of a massive (spinning) source in twistor terms, it will be convenient first to discuss the 2-index twistor $A^{\alpha\beta}$ which represents its energy-momentum and angular momentum. Generally, let P_a be the momentum and M^{ab} the angular momentum with respect to an origin O , of some finite physical system in special relativity. Normally P_a will be timelike (future-pointing) so the twistor description of sections 1.3 and 2.1 does not directly apply. But we can always represent (P_a, M^{ab}) for such cases (in many ways) as a sum of a finite number of (P_a, M^{ab}) of the type for which the twistor description (1.32), (1.34) does directly apply – i.e. for which the momentum is null and future-pointing and with the spin-vector proportional to it. In fact, we need only two, $(\dot{P}_a, \dot{M}^{ab})$ and $(\ddot{P}_a, \ddot{M}^{ab})$, say, so

$$P_a = \dot{P}_a + \ddot{P}_a, \quad M^{ab} = \dot{M}^{ab} + \ddot{M}^{ab} \tag{5.30}$$

where $(\dot{P}_a, \dot{M}^{ab})$ is constructed from twistors $(\dot{\omega}^A, \dot{\pi}_{A'})$ according to (1.32) and (1.34). This can be achieved in many ways as is not hard to verify explicitly.

Now, the expressions (1.32) and (1.34) for the momentum and angular momentum in terms of a single twistor $Z^\alpha \leftrightarrow (\omega^A, \pi_{A'})$ are

$$P_a = \bar{\pi}_A \pi_{A'}, \quad M^{ab} = i\omega^{(A} \bar{\pi}^{B)} \epsilon^{A'B'} - i\epsilon^{AB} \bar{\omega}^{(A'} \pi^{B')} \tag{5.31}$$

These quantities are equivalent to a subset of the components of $Z^\alpha \bar{Z}_\beta$. They are defined once $\pi_{A'} \bar{\pi}^B$ and $\omega^{(A} \bar{\pi}^{B)}$ are known, i.e. once the symmetrized outer product of $(\omega^A, \pi_{A'})$ with $(\bar{\pi}^B, 0)$ is known. We have $I^{\beta\gamma} \bar{Z}_\gamma \leftrightarrow (\bar{\pi}^B, 0)$ (compare (5.22)) so the angular momentum twistor

$$A^{\alpha\beta} = 2Z^{(\alpha} I^{\beta)\gamma} \bar{Z}_\gamma \leftrightarrow \begin{pmatrix} 2\omega^{(A} \bar{\pi}^{B)} & \bar{\pi}^A \pi_{B'} \\ \pi_{A'} \bar{\pi}^B & 0 \end{pmatrix} \tag{5.32}$$

may be used to describe the 4-momentum and angular-momentum in the null case. In the general timelike case we can extend this by linearity. Thus, the angular momentum twistor, quite generally, is

$$A^{\alpha\beta} \leftrightarrow \begin{pmatrix} -2i\mu^{AB} & P^A_{B'} \\ P_{A'}^B & 0 \end{pmatrix} \tag{5.33}$$

where

$$M^{ab} = \mu^{AB} \epsilon^{A'B'} + \epsilon^{AB} \mu^{A'B'}; \quad \mu^{AB} = \mu^{BA}. \tag{5.34}$$

We have $A^{\alpha\beta}$ of the form

$$A^{\alpha\beta} = 2E_\gamma^{(\alpha} I^{\beta)\gamma} \tag{5.35}$$

where

$$E_\beta^\alpha = \sum_i \dot{Z}^\alpha \bar{Z}_\beta^i \tag{5.36}$$

the various \dot{Z}^α being the twistors representing the different null-momentum systems into which our general system has been decomposed (e.g. for (5.30) we have $E_\beta^\alpha = \dot{Z}^\alpha \bar{Z}_\beta^1 + \ddot{Z}^\alpha \bar{Z}_\beta^2$). Note that E_β^α has the Hermitian property

\bar{E}_β^α

(The left-hand

W_c

as follows at

A^α

Conversely, (ness (5.38) is

V_α

Indeed, the s

(5.38), is also

Note that

E_β^α

makes no dif

would be affi

unique. In fa

E_β^α

(ignoring the

S^α

Let us now c

A^α

defined in du

by Kerr's the

{W

When the spi

the world lin

spin, the con

vacuum solut

esses a local

directions, at

precisely the "pr

the flagpole c

It is the fu

generating a s

(moment) sou

$$\bar{E}_\beta^\alpha = E_\beta^\alpha. \tag{5.37}$$

(The left-hand side is, of course, $\overline{E_\alpha^\beta}$.) It also has the semi-definiteness property

$$W_\alpha E_\beta^\alpha \bar{W}^\beta \geq 0 \quad \text{for all } W_\alpha \tag{5.38}$$

as follows at once from (5.36). The form (5.35), together with (5.37), implies

$$A^{\alpha\beta} = A^{\beta\alpha}, \quad A^{\alpha\gamma} I_{\beta\gamma} = \bar{A}_{\beta\gamma} I^{\alpha\gamma}. \tag{5.39}$$

Conversely, (5.39) implies the existence of E_β^α for which (5.35) and (5.37) hold. The semi-definiteness (5.38) implies that

$$V_\alpha A^{\alpha\gamma} I_{\beta\gamma} \bar{V}^\beta \geq 0 \quad \text{for all } V_\alpha. \tag{5.40}$$

Indeed, the second relation in (5.39) is also implied by (5.40) and the *existence* of E_β^α , subject to (5.38), is also implied by this.

Note that removal of the trace from E_β^α :

$$E_\beta^\alpha \rightarrow E_\beta^\alpha - \frac{1}{4} E_\gamma^\gamma \delta_\beta^\alpha \tag{5.41}$$

makes no difference to (5.35) (owing to the skew-symmetry of $I^{\alpha\beta}$) although the relation (5.38) would be affected. Given $A^{\alpha\beta}$ satisfying (5.39), the choice of E_β^α in (5.35) is clearly very far from unique. In fact, the "gauge freedom" in E_β^α is

$$E_\beta^\alpha \rightarrow E_\beta^\alpha + S^{\alpha\gamma} I_{\beta\gamma} + \bar{S}_{\beta\gamma} I^{\alpha\gamma} \tag{5.42}$$

(ignoring the semi-definiteness (5.38)) where

$$S^{\alpha\beta} = -S^{\beta\alpha}. \tag{5.43}$$

Let us now consider the quadratic function

$$A^{\alpha\beta} W_\alpha W_\beta \tag{5.33}$$

defined in dual twistor space. Since this is holomorphic and homogeneous, its vanishing defines, by Kerr's theorem (cf. [5]), the shear-free congruence of null straight lines

$$\{W: A^{\alpha\beta} W_\alpha W_\beta = 0 = W_\alpha \bar{W}^\alpha, W_\alpha \neq 0\}. \tag{5.44}$$

When the spin vector (1.29) vanishes, this congruence consists of all the null lines which intersect the world line of the relativistic mass centre (see section 1.3). In the general case of a system with spin, the congruence is of the more general kind considered by Kerr [47] (in connection with his vacuum solution of Einstein's equations representing a rotating black hole). The congruence possesses a local rotation if and only if the system has a non-zero spin. It also turns out that the null directions, at each point in space-time, which are tangent to the lines of the congruence are precisely the "principal null directions" [9, 46] of the angular momentum tensor M^{ab} . (These are the flagpole directions of λ^A and ν^A , where $\mu^{AB} = \lambda^A \nu^B$.)

It is the function (5.44) which also enters into the definition of a passive holomorphic function generating a solution of Maxwell's equations surrounding a charged spinning (i.e. with magnetic moment) source, or a solution of the linearized Einstein equations (the linearized Schwarzschild

or Kerr solution) for a massive spinning source. In fact, putting

$$f(W) = (A^{\alpha\beta}W_\alpha W_\beta)^{-2} \quad \text{and} \quad g(W) = (A^{\alpha\beta}W_\alpha W_\beta)^{-3}$$

we have f homogeneous of degree -4 (as required for the construction of a Maxwell field) and g homogeneous of degree -6 (as required for the construction of a linearized gravitational field). We have already noted, in section 2.3, that when $g(W)$ is the inverse cube of a quadratic form, then the resulting linearized gravitational field has algebraic type $\{2,2\}$ — as happens to be the case for a (linearized) Schwarzschild or Kerr solution. It is indeed true that the functions do yield fields of stationary sources of the required type. When the rotation vanishes, we get monopole solutions (Coulomb in the electromagnetic case and linearized Schwarzschild in the gravitational case).

Let $B_{\alpha\beta}$ be inverse to $A^{\alpha\beta}$,

$$A^{\alpha\beta}B_{\beta\gamma} = \delta_\gamma^\alpha, \tag{5.46}$$

and put

$$\Delta = \{\det A^{\alpha\beta}\}^{1/2} = \{\det B_{\alpha\beta}\}^{-1/2}. \tag{5.47}$$

(Only in the case of a null momentum is $A^{\alpha\beta}$ singular. We shall ignore this case henceforth.) One verifies at once that the properties

$$B_{\alpha\beta} = B_{\beta\alpha}, \quad B_{\alpha\gamma}I^{\beta\gamma} = \bar{B}^{\beta\gamma}I_{\alpha\gamma} \tag{5.48}$$

and

$$X^\alpha B_{\alpha\gamma}I^{\beta\gamma}\bar{X}_\beta \geq 0 \quad \text{for all } X^\alpha \tag{5.49}$$

follow directly from (5.46) and the corresponding properties (5.39) and (5.40) for $A^{\alpha\beta}$. Also Δ is real:

$$\Delta = \bar{\Delta}. \tag{5.50}$$

The condition for the absence of rotation turns out to be

$$\bar{A}_{\alpha\beta} = B_{\alpha\beta}\Delta. \tag{5.51}$$

The charge integral for an electromagnetic field was briefly mentioned in section 3.3. This was $\oint f(W)DW$ (with some constant multiplying factor). Here we have

$$\epsilon = \oint f(W)DW = \pi^2\Delta^{-1}. \tag{5.52}$$

The contour can be conveniently chosen to be an S^3 . Similarly, the integral giving the energy-momentum and angular momentum for the source of a linearized gravitational field is $\oint W_\alpha W_\beta g(W)DW$ which here gives:

$$\oint W_\alpha W_\beta g(W)DW = \frac{1}{4}\pi^2 B_{\alpha\beta}\Delta^{-1} \tag{5.53}$$

(although here Δ^{-1} measures the rest-mass rather than the charge). This may be obtained by differentiating (5.52) with respect to $A^{\alpha\beta}$ (temporarily dropping the constraints (5.39)) since

$$\partial f / \partial A^{\alpha\beta} = -2W_\alpha W_\beta g \tag{5.54}$$

and

$$\frac{\partial \Delta}{\partial A^{\alpha\beta}} = \frac{1}{2} B_{\beta\alpha} \Delta, \quad \frac{\partial B_{\alpha\beta}}{\partial A^{\gamma\delta}} = -B_{\alpha\gamma} B_{\delta\beta}. \tag{5.55}$$

Notice the reversal of roles of $A^{\alpha\beta}$ and $B_{\alpha\beta}$ here. The angular momentum twistor arising here is actually (proportional to) $\bar{B}^{\alpha\beta}$.

We wish to consider scattering of charged massless particles off the electromagnetic field whose passive twistor function is $f(W_\beta)$. To compute the Hamiltonian we need to evaluate the integral for the active function³⁴:

$$\tilde{f}(Z^\alpha) = \oint (W \cdot Z)_0 f(W_\beta) \mathcal{D}W. \tag{5.46}$$

Since this involves the formal expression $(W \cdot Z)_0$ we had best differentiate with respect to Z^α :

$$\partial \tilde{f} / \partial Z^\alpha = \oint W_\alpha (W \cdot Z)_1 f(W) \mathcal{D}W. \tag{5.47}$$

This is now well-defined. The singularity structure is different from that of (5.52) since there is the extra pole arising from $(W \cdot Z)_1$. This pole gets in the way of the previous contour but, remarkably, a new contour emerges which links the new pole and is not homologous to zero. A similar phenomenon occurs again if another pole $(W \cdot Y)_1$ is inserted into the integral and once more if yet another pole $(W \cdot X)_1$ is inserted. (To ensure uniqueness of the contour up to homology class, we must insist that each pole is "linked" once in a "positive" sense.) It is worthwhile to list the results of some relevant integrals

$$\oint \frac{W_\alpha \mathcal{D}W}{W_\beta Z^\beta (A^{\rho\sigma} W_\rho W_\sigma)^2} = \frac{2\pi^2}{\Delta} \frac{B_{\alpha\beta} Z^\beta}{B_{\rho\sigma} Z^\rho Z^\sigma} \tag{5.49}$$

$$\oint \frac{\mathcal{D}W}{W_\alpha Y^\alpha W_\beta Z^\beta (A^{\rho\sigma} W_\rho W_\sigma)} = 8\pi^3 \{2\epsilon_{\alpha\beta\gamma\delta} \epsilon_{\lambda\mu\rho\sigma} A^{\alpha\lambda} A^{\beta\mu} Y^\gamma Z^\delta Y^\rho Z^\sigma\}^{-1/2} \tag{5.50}$$

$$\oint \frac{W_\alpha \mathcal{D}W}{W_\beta X^\beta W_\gamma Y^\gamma W_\delta Z^\delta (A^{\rho\sigma} W_\rho W_\sigma)} = 8\pi^3 i \frac{\epsilon_{\alpha\beta\gamma\delta} X^\beta Y^\gamma Z^\delta}{\epsilon_{\xi\lambda\mu\nu} \epsilon_{\eta\rho\sigma\tau} A^{\xi\eta} X^\lambda Y^\mu Z^\nu X^\rho Y^\sigma Z^\tau}. \tag{5.51}$$

The integral (5.59) supplies the answer to (5.57) which we can immediately integrate to obtain (formally)

$$\tilde{f}(Z) = \frac{\pi^2}{\Delta} (B_{\alpha\beta} Z^\alpha Z^\beta)_0 = \epsilon \log(B_{\alpha\beta} Z^\alpha Z^\beta). \tag{5.52}$$

Our twistor scattering Hamiltonian is

$$H(Z^\alpha, \bar{Z}_\beta) = \tilde{f}(Z^\alpha) + \tilde{f}(\bar{Z}_\beta), \tag{5.53}$$

³⁴It turns out that for functions of the singularity structure considered here (unlike the case of a free wave) this operation can be inverted. In fact, we have $\tilde{\tilde{f}} = f$.

which gives

$$\delta\bar{Z}_\alpha = 2i\epsilon B_{\alpha\beta}Z^\beta/B_{\rho\sigma}Z^\rho Z^\sigma. \quad (5.64)$$

Inserting explicit coordinates into this formula we obtain the correct lowest order "1/r" deflection angle. Also (5.64) gives the correct lowest order time delay – which turns out to be a constant independent of the impact parameter.

In a similar way the gravitational case can be treated. The final result is

$$\delta\bar{Z}_\alpha \propto \frac{1}{\Delta} \left(B_{\alpha\gamma}I^{\beta\gamma}\bar{Z}_\beta \log|B_{\rho\sigma}Z^\rho Z^\sigma|^2 + \frac{B_{\alpha\beta}Z^\beta B_{\rho\sigma}I^{\rho\sigma}Z^\rho\bar{Z}_\tau}{B_{\lambda\mu}Z^\lambda Z^\mu} \right)$$

which must be considered formal, to some extent, because of the logarithm term. The logarithm only affects the time delay, the scattering angle being given by the second term. This second term is identical in form with that for the electromagnetic case except for the momentum factor

$$B_{\rho\sigma}I^{\rho\sigma}Z^\rho\bar{Z}_\tau.$$

This simply ensures that the scattering angle is independent of the momentum of the scattered particle (since the whole term now has the same homogeneity degree as $\delta\bar{Z}_\alpha$) in accordance with the equivalence principle. Owing to the logarithm term there is no meaningful ("invariant") absolute concept of time delay. This is borne out by examination of the null orbits in the Schwarzschild solution. The time delay involves a similar logarithm term which diverges to minus infinity for large impact parameters.

Finally there is the question of how to obtain the correct quantum versions of these scattering problems using twistor methods. Blindly inserting the Hamiltonian into the formula $\langle p|q \rangle$ for the scalar product does not yield the correct matrix elements but gives zero instead. It appears that potentials must be brought in in order to obtain the correct results. A method of introducing potentials into twistor theory is given in the next section.

5.3. Potentials and massive fields

The fundamental formula (2.20) for a solution (in flat space) of the spin $\frac{1}{2}n$ zero-rest-mass field equation $\nabla^{PP'}\phi_{PP'..S} = 0$, in terms of a general holomorphic function $f(W_\alpha)$ homogeneous of degree $-n-2$ in the components of the twistor W_α may be re-expressed as follows:

$$\phi_{PQ..S}(x^a) = \frac{1}{2\pi i} \oint \lambda_P\lambda_Q\dots\lambda_S f(\lambda_A, -ix^{AA'}\lambda_A) \mathcal{D}\lambda \quad (5.65)$$

where

$$\mathcal{D}\lambda = \epsilon^{AB}\lambda_A d\lambda_B$$

(cf. (3.35)). The verification that the zero rest-mass equations are indeed satisfied is now very direct since

$$\frac{\partial}{\partial x^{TT'}}\phi_{PQ..S} = \frac{1}{2\pi i} \oint -i\lambda_P\lambda_Q\dots\lambda_S\lambda_T f_T(\lambda_A, -ix^{AA'}\lambda_A) \mathcal{D}\lambda$$

is manifestly symmetric in $PQ\dots ST$, where

$$(5.64) \quad \partial f / \partial W_\alpha \leftrightarrow (f^A, f_{A'}).$$

The formula (5.65) allows an immediate generalization to functions $F(W_\alpha; Z^\alpha)$, holomorphic in two twistors W_α, Z^α , and homogeneous of respective degrees $-p-2$ and $-q-2$. We can set

$$\alpha_{P\dots SG' \dots K'}(x^a) = \frac{1}{(2\pi i)^2} \oint \underbrace{\lambda_P \dots \lambda_S}_p \underbrace{\mu_{G'} \dots \mu_{K'}}_q F(\lambda_A, -ix^{AA'} \lambda_A; ix^{AA'} \mu_{A'}, \mu_{A'}) \mathcal{D}\lambda \mu \quad (5.66)$$

(where $\mathcal{D}\lambda \mu = \mathcal{D}\lambda \wedge \mathcal{D}\mu$ etc.; cf. (3.34)). Then, since $\partial \alpha_{\dots} / \partial x^{TT'}$ is the sum of a term symmetric in its unprimed indices and a term symmetric in its primed indices, it follows that

$$\nabla^{PG'} \alpha_{PQ \dots SG' \dots K'} = 0. \quad (5.67)$$

Note that α_{\dots} depends on $F(W_\alpha; Z^\alpha)$ where $W_\alpha Z^\alpha = 0$ only. (One can also generalize in an obvious way to obtain two-point fields $\alpha_{P \dots SG' \dots K'}(x^a, y^b)$ satisfying $\partial \alpha_{P \dots SG' \dots K'} / \partial x^{P'} = 0, \partial \alpha_{P \dots SG' \dots K'} / \partial y^{G'} = 0$. These fields reduce to the previous ones if we set $y^a = x^a$, but they depend on $F(W_\alpha; Z^\alpha)$ also where $W_\alpha Z^\alpha \neq 0$.)

The equation (5.67) has considerable interest. When $p = q = 1$ it reduces to $\nabla^{PG'} \alpha_{PG'} = 0$, which is the Lorenz gauge condition if α_a is the electromagnetic potential. We can then define the electromagnetic field spinor by $\phi_{AB} = \nabla_A^C \alpha_{BC}$, and symmetry in AB is ensured. More generally, (5.67) implies that

$$\beta_{P \dots STH' \dots K'} = \nabla_T^{G'} \alpha_{P \dots SG'H' \dots K'} \quad (5.68)$$

is symmetric in $P\dots ST$ and that

$$\gamma_{Q \dots SG' \dots K'L'} = \nabla_L^P \alpha_{PQ \dots SG' \dots K'} \quad (5.69)$$

is symmetric in $G' \dots K'L'$ where we use the fact that $\alpha_{P \dots SG' \dots K'}$ is symmetric in $P\dots S$ and in $G' \dots K'$. Furthermore, each of β_{\dots} and γ_{\dots} also satisfies (5.67) ($\nabla^{PH'} \beta_{P \dots TH' \dots K'} = 0, \nabla^{QG'} \gamma_{Q \dots SG' \dots L'} = 0$).

Indeed, they each arise from a formula like (5.66), in which $F(W_\alpha; Z^\alpha)$ is replaced, respectively, by³⁵

$$-iI_{\rho\sigma} Z^\rho \partial F / \partial W_\sigma \quad \text{or} \quad iP^\sigma W_\rho \partial F / \partial Z^\sigma. \quad (5.70)$$

Note that the operation (5.68) increases the number of unprimed indices by one and decreases the number of primed indices by one, while the operation (5.69) does just the reverse. If we follow one operation by the other, the result is simply equivalent to application of $-\frac{1}{2}\square$, where $\square = \nabla^q \nabla_q$ is the flat space D'Alembertian. Thus, we have, for the twistor translation of the D'Alembertian:

$$\square = -2 \left(I_{\alpha\beta} Z^\alpha \frac{\partial}{\partial W_\beta} \right) \circ \left(I^{\rho\sigma} W_\rho \frac{\partial}{\partial Z^\sigma} \right) = -2 I_{\alpha\beta} Z^\alpha I^{\rho\sigma} W_\rho \frac{\partial^2}{\partial W_\beta \partial Z^\sigma}. \quad (5.71)$$

³⁵The observation that potential functions for zero rest-mass fields could be described by holomorphic functions of W_α and Z^α related by (5.70) had already been made by C.J.S. Clarke.

Employing the quantum mechanical replacements $-\partial/\partial Z^\alpha \leftrightarrow \bar{Z}_\alpha$, $\partial/\partial W_\beta \leftrightarrow \bar{W}^\beta$ and $\square \leftrightarrow -m^2$, we obtain

$$m^2 = 2|I_{\alpha\beta}Z^\alpha\bar{W}^\beta|^2. \quad (5.72)$$

It is reassuring that this agrees with the formula for the total mass of a system which, as in section 5.2, is composed of two systems each of zero rest-mass, namely that arising from Z^α and that arising from W_α . We have $P_a = \bar{Z}_A Z_{A'} + W_A \bar{W}_{A'}$, so $P_a P^a = 2|Z_A \bar{W}^{A'}|^2$ whence (5.72) follows.

If $F(W_\alpha, Z^\alpha)$ is an eigenstate with eigenvalue $-m^2$ of the operation (5.71), then the resulting field α_{\dots} defined by (5.66) satisfies $(\square + m^2)\alpha_{\dots} = 0$. This equation, together with (5.67), implies that α_{\dots} (paired up with β_{\dots} of (5.68) or with γ_{\dots} of (5.69) if desired) describes a Dirac irreducible "higher spin" free field of mass m (assumed positive, for the moment), and spin $\frac{1}{2}(p+q)$. (If $pq=0$, then (5.67) becomes vacuous and is not needed. This applies, in particular to the normal Dirac equation for the electron, for which $p=1, q=0$ or $p=0, q=1$.) Thus, we have the potentiality to describe states of particles with non-zero rest-mass within the twistor formalism.

When $m=0$ we have a way of describing the potentials directly in twistor terms. This gives a means of introducing interactions in a much more direct way than had been possible hitherto within the twistor formalism³⁶. We are not now forced into considering only source-free fields, since the application of the operator (5.71) to F can give the source terms.

If $m=0$ and sources are absent, it should be possible to obtain a function $F(W_\alpha)$ generating the field $\phi_{p\dots s}$ as in (5.65) from the function $F(W_\alpha; Z^\alpha)$ generating the same field as in (5.66) with $q=0$. Provided $F(\lambda_A, -ix^{AA'}\lambda_{A'}, iy^{AA'}\mu_{A'}, \mu_{A'})$ is independent of y^a , i.e. provided $I^{\alpha\beta}\partial F/\partial Z^\beta = 0$, we can write this

$$f(W_\alpha) = \frac{1}{2\pi i} \oint F(W_\alpha; iy^{AA'}\mu_{A'}, \mu_{A'}) \mathcal{D}\mu.$$

References

- [1] R. Penrose, in *Combinatorial mathematics and its applications*, ed. D.J.A. Welch (Academic Press, London, 1971).
- [2] R. Penrose, *Battelle Rencontres 1967*, eds. C.M. de Witt and J.A. Wheeler (Benjamin, New York 1968).
- [3] N.H. Kuiper, *Ann Math.* 50 (1949) 916;
H. Rudberg, *Dissertation*, University of Uppsala, Sweden 1958;
R. Penrose, in *Proc. 1962 Conf. on Relativistic theories of gravitation*, Warsaw (Polish Academy of Science, Warsaw 1965);
A. Uhlmann, *Acta Phys. Polon.* 24 (1963) 293.
- [4] R. Penrose, *Proc. Roy. Soc. (London) A* 284 (1965) 159.
- [5] R. Penrose, *J. Math. Phys.* 8 (1967) 345.
- [6] E. Cartan, *Ann. Ecole Norm. Super.* 31 (1914) 263;
F. Klein, *Gesammelte Math. Abh.* (J. Springer, Berlin 1921);
H. Weyl, *The classical groups* (Princeton University Press, Princeton, New Jersey 1939);
R. Brauer and H. Weyl, *Amer. J. Math.* 57 (1935) 425.
- [7] L.P. Eisenhart, *Continuous groups of transformations* (Princeton University Press 1933, reprinted by Dover 1961).
- [8] H. Laue, *Nuovo Cimento* 38 (1971) 55.
- [9] R. Penrose, *Ann. Phys. (N.Y.)* 10 (1960) 171;
E.T. Newman and R. Penrose, *J. Math. Phys.* 3 (1962) 566.

³⁶In particular the Möller scattering formula (fig. 11) discussed in section 4.1 can now be completely justified.

R.
[10] E.T. Wh
W.T. Pa
[11] R. Penr
U.S. Ab
[12] P.A.M.
M. Fier
E.P. Wit
[13] E. Cunr
H. Bate
J.A. Mc
H.A. Bu
[14] R.K. Sa
[15] B.L. var
[16] W.A. He
Y. Mure
I.E. Seg
[17] H. Bonc
H. Bonc
R.K. Sa
[18] E.T. Ne
[19] E. Grgi
[20] J.A. To
J.G. Ser
[21] R. Penr
[22] I. Robin
[23] N. Kop
[24] R. Penr
[25] R.F. St
[26] M. Cran
[27] N.J. Hik
[28] W.H. Br
J. Ehler
[29] R. Penr
Press, C
[30] M. Fier
[31] I. Robin
[32] A. Qadi
[33] R. Penr
[34] T. Fult
[35] A. Trau
1964, v
[36] L. Gros
[37] R. Penr
[38] R. Penr
[39] M. Flato
H. Kast
[40] L. Infel
[41] R. Penr
and Gla
[42] R. Penr
Island 1
[43] E.T. Ne
[44] B. Aron
[45] S. Helge
E. Nelsc
[46] J.L. Syr
[47] R.P. Ke
[48] J.D. Bjc

$\leftrightarrow -m^2$, we
 (5.72)
 ch, as in section
 γ^α and that
 follows.
 the resulting
 (5.67), implies
 Dirac irreducible
 $p + q$. (If $pq = 0$,
 normal Dirac
 e potentiality
 . This gives a
 de hitherto
 ce-free fields,
) generating the
 (5.66) with
 $J^{\alpha\beta}\partial F/\partial Z^\beta = 0$,
 on, 1971).
 ice, Warsaw 1965);
 ver 1961).
 l.

[10] E.T. Whittaker, Proc. Roy. Soc. (London) A 158 (1937) 38;
 W.T. Payne, Amer. J. Phys. 20 (1952) 253.
 [11] R. Penrose, Null hypersurface initial data, in A.R.L. Techn. Report 63-56, ed. P.G. Bergmann (Office of Aerospace Research,
 U.S. Air Force 1963).
 [12] P.A.M. Dirac, Proc. Roy. Soc. (London) A 155 (1936) 447;
 M. Fierz and W. Pauli, Proc. Roy. Soc. (London) A 173 (1939) 211;
 E.P. Wigner and V. Bargmann, Proc. Nat. Acad. Sci. (Washington) 34 (1948) 211.
 [13] E. Cunningham, Proc. London Math. Soc. 8 (1910) 77;
 H. Bateman, Proc. London Math. Soc. 8 (1910) 223;
 J.A. McLennan Jr., Nuovo Cimento 10 (1956) 1360;
 H.A. Buchdahl, Nuovo Cimento 11 (1959) 496.
 [14] R.K. Sachs and P.G. Bergmann, Phys. Rev. 112 (1958) 674.
 [15] B.L. van der Waerden, Nachrichten von der Gesellschaft der Wiss. Gottingen (1929) 100.
 [16] W.A. Hepner, Nuovo Cimento 26 (1962) 351;
 Y. Murai, Prog. Theoret. Phys. 9 (1953) 147; 11 (1954) 441 and Nucl. Phys. 6 (1958) 489;
 I.E. Segal, Proc. Nat. Acad. Sci. (Washington) 57 (1967) 194.
 [17] H. Bondi, Nature 186 (1960) 535;
 H. Bondi, A.W.K. Metzner and M.J.G. van der Burg, Proc. Roy. Soc. (London) A 269 (1962) 21;
 R.K. Sachs, Proc. Roy. Soc. (London) A 270 (1962) 103.
 [18] E.T. Newman and T.W.J. Unti, J. Math. Phys. 3 (1962) 891.
 [19] E. Grigin, Ph.D. thesis, Syracuse University (1966).
 [20] J.A. Todd, Projective and analytic geometry (Pitman, London 1947);
 J.G. Semple and L. Roth, Introduction to algebraic geometry (Clarendon Press, Oxford 1949).
 [21] R. Penrose, Int. J. Theor. Phys. 1 (1968) 61.
 [22] I. Robinson, J. Math. Phys. 2 (1961) 290.
 [23] N. Kopczynski and L.S. Woronowicz, Reports Math. Phys. 2 (1971) 35.
 [24] R. Penrose, J. Math. Phys. 10 (1969) 38.
 [25] R.F. Streater and A.S. Wightman, *PCT, spin statistics and all that* (Benjamin, New York 1964).
 [26] M. Crampin and F.A.E. Pirani, in *Relativity and gravitation*, eds. Ch.G. Kuper and A. Peres (Gordon and Breach, London 1971).
 [27] N.J. Hicks, *Notes on differential geometry* (Van Nostrand, Princeton 1965).
 [28] W.H. Brinkmann, Proc. Natl. Acad. Sci. (Washington) 9 (1923) 1; see also
 J. Ehlers and W. Kundt, in *Gravitation; an introduction to current research*, ed. L. Witten (John Wiley, New York 1962) ch. 2.
 [29] R. Penrose, *General relativity* (Papers in honour of J.L. Synge), ed. L. O'Riartaigh for the Royal Irish Academy (Clarendon
 Press, Oxford 1972).
 [30] M. Fierz, Helv. Phys. Acta 13 (1940) 45.
 [31] I. Robinson and A. Trautman, Proc. Roy. Soc. (London) A 265 (1962) 463.
 [32] A. Qadir, Ph.D. thesis, Birkbeck College, London (1971).
 [33] R. Penrose, *An analysis of the structure of spacetime* (Adams Prize Essay, Princeton 1967).
 [34] T. Fulton, F. Rohrlich and L. Witten, Rev. Mod. Phys. 34 (1962) 442.
 [35] A. Trautman, F.A.E. Pirani and H. Bondi, *Lectures on general relativity*, Brandeis Summer Institute in Theoretical Physics,
 1964, vol. 1 (Prentice-Hall, Englewood Cliffs, New Jersey 1965).
 [36] L. Gross, J. Math. and Phys. 5 (1963) 687.
 [37] R. Penrose, in *Quantum theory and beyond*, ed. E.T. Bastin (Cambridge University Press 1972).
 [38] R. Penrose, in *Magic without magic: John Archibald Wheeler*, ed. J.R. Klauder (W.H. Freeman & Co., San Francisco 1972).
 [39] M. Flato, J. Simon and D. Sternheimer, Ann. Phys. (N.Y.) 61 (1970) 78;
 H. Kastrupp, Phys. Rev. 142 (1966) 1060.
 [40] L. Infeld and B.L. van der Waerden, Sitz. ber. Preuss. Akad. 9 (1933) 380.
 [41] R. Penrose, in *Relativity, groups and topology*, eds. C and B. deWitt, Les Houches lectures 1963 (Blackie and Son, London
 and Glasgow 1964).
 [42] R. Penrose, in *Relativity theory and astrophysics vol. 1*, ed. J. Ehlers (American Mathematical Society, Providence, Rhode
 Island 1967).
 [43] E.T. Newman and R. Penrose, Proc. Roy. Soc. (London) A 305 (1968) 175.
 [44] B. Aronson, R. Lind, J. Messmer and E.T. Newman, J. Math. Phys. 12 (1971) 2462.
 [45] S. Helgason, *Differential geometry and symmetric spaces* (Academic Press, New York 1962);
 E. Nelson, *Tensor analysis, Mathematical Notes* (Princeton University Press 1967).
 [46] J.L. Synge, *Relativity; the special theory* (North-Holland, Amsterdam 1956).
 [47] R.P. Kerr, Phys. Rev. Letters 11 (1963) 237.
 [48] J.D. Bjorken and S.D. Drell, *Relativistic quantum fields* (McGraw-Hill, New York 1965).