

HOW TO TEACH QUANTUM MECHANICS¹

David Albert
Columbia University

Abstract

I distinguish between two conceptually different kinds of physical space: a space of *ordinary material bodies*, which is the space of points at which I could imaginably place (say) the tip of my finger, or the center of a billiard-ball, and a space of *elementary physical determinables*, which is the smallest space of points such that stipulating what is happening at each one of those points, at every time, amounts to an exhaustive physical history of the universe. In all *classical* physical theories, these two spaces happen to coincide – and what we *mean* by calling a theory “classical”, and *all* we mean by calling a theory “classical”, is (I will argue) precisely *that* these two spaces coincide. But once the distinction between these two spaces is on the table, it becomes clear that there is no logical or conceptual reason why they *must* coincide – and it turns out (and this is the main topic of the present paper) that a very simple way of *pulling them apart* from one another gives us *quantum mechanics*.

What I want to show here, by means of a few very simple mechanical examples, is (in a nutshell) that everything that has always struck everybody as strange about quantum mechanics can be explained by supposing that the concrete fundamental physical *stuff* of the world is floating around in something other, and larger, and different, than the familiar 3-dimensional space of our everyday experience.

¹ I’m thankful to Jill North (and of course, more indirectly, to John Bell) for suggesting this title.

1

Let me begin by introducing a useful mathematical device with which some readers may be unfamiliar.

Every classical physical system can be uniquely associated with a formula called its *Hamiltonian*, which expresses the total *energy* of the system in question – which expresses (that is) the sum of the *kinetic* and the *potential* parts of the energy of the system in question - as a function of the values of its physical degrees of freedom, and of the values of various of the *derivatives* of its physical degrees of freedom.

And it turns out – and this is why the Hamiltonian is such a useful device - that the Hamiltonian of a classical system concisely encodes *everything there is to say* about the *dynamical laws of motion* that that system obeys. It turns out (that is) that the way that the total energy of such a system depends on its degrees of freedom – and on various of the derivatives of those degrees of freedom - uniquely determines the equations of the evolutions of the values of those degrees of freedom in time. It turns out (that is) that there is a direct and straightforward and fully algorithmic procedure for *deriving* those equations – for any classical system - *from* its Hamiltonian.

To say that the Hamiltonian tells us everything about the *dynamical laws* of a classical system (however) is not quite to say that it tells us exactly what *kind* of a classical system it is that we are dealing with. Consider, for example, a very simple Hamiltonian – one that consists exclusively of *kinetic* energy terms - like:

$$H = \frac{1}{2}m(d^2x_1(t)/dt^2) + \frac{1}{2}m(d^2x_2(t)/dt^2) \quad (1)$$

This Hamiltonian fixes the dynamical laws of a system with 2 degrees of freedom – the two $x_i(t)$. But there are two quite different sorts of physical systems that a Hamiltonian like this one could very naturally be read as describing. We could read it (that is) as describing a *pair* of particles, both of mass m , moving around, in the absence of any forces, and without interacting in any way with one another, in a *one-dimensional* space. Or we could read it as describing a *single* particle, of mass m , moving around, in the absence of any forces, in an otherwise empty *two-dimensional* space. All that the *Hamiltonian* does is to determine the differential equations that each of the two $x_i(t)$ need to satisfy. All that the Hamiltonian does – in this particular case – is to determine that

$$x_i(t) = a_i + v_i t \quad (2)$$

where a_i and v_i can be any real numbers. And that's precisely the sort of behavior that we would intuitively expect of *either one* of the two different physical systems described above.

*

Good. Let's make things a little more complicated.

Consider (again) a classical universe with two physical degrees of freedom – x_1 and x_2 – but now suppose that the values of x_1 and x_2 evolve in time in accord with the Hamiltonian

$$H = (1/2m_1)(dx_1(t)/dt)^2 + (1/2m_2)(dx_2(t)/dt)^2 + \delta(x_1-x_2). \quad (3)$$

This Hamiltonian differs from the one in equation (1) in two important ways: it includes a very simple potential-energy term - $\delta(x_1-x_2)$ – and it allows for the possibility that the values of m in the two *kinetic*-energy terms may be *different*.

Here are two different ways of describing a universe whose dynamical laws are given by a Hamiltonian like the one in equation (3):

A) The universe consists of two point-like physical items, moving around in a one-dimensional space, and interacting with one another, on contact, by means of elastic collisions.

B) The universe consists of a *single* point-like physical item, moving around in a *two*-dimensional space, with an infinite potential barrier along its $x_1 = x_2$ diagonal – as in Figure 1.

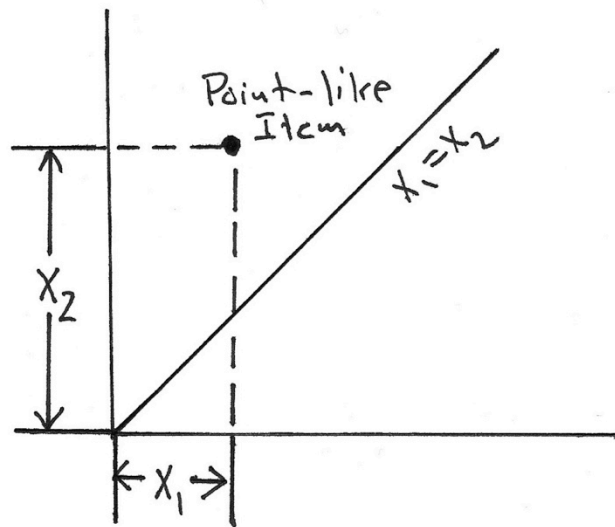

Figure 1

These two descriptions – like the two descriptions we considered in connection with the Hamiltonian in equation (1) – are fully mathematically isomorphic to one another. But in this case, *unlike* in the previous one, the two descriptions are not apt to strike us as equally *natural*. Take almost anybody, with almost any kind of an education in physics, and wake them up in the middle of the night, and ask them to describe the sort of world that might have a Hamiltonian like the one in equation (3)

as its fundamental law of motion – and you are likely to get something that’s much closer to the language of description (A) than it is to the language of description (B). And the reasons for that will be worth pausing over, and thinking about.

To begin with, the *mass* associated with the kinetic energy of x-motion and the mass associated with the kinetic energy of y-motion – in the example we are considering here - are *different*. And we are used to associating a *single* mass with a single material object. You might even say that it is part and parcel of our very *idea* of what it *is* to be an ‘ordinary material object’ that every such object is invariably associated with some single, determinate, value of it’s mass. And our everyday conception of the *world* seems to have something to do with it’s being the *habitation* of objects like that. And our everyday conception of *space* seems to have something to do with the set of points at which an ordinary material object might in principle be *located*, or with the *stage* on which such objects seem to make their way *about*.

Good. But what if the masses happen to be the same? Won’t it be just as natural (in *that* case) to think of this universe as consisting of a single material particle, moving around in a 2-dimensional space, with an infinite potential barrier along the diagonal line $x_1=x_2$?

Well, no. There are other issues here as well. It seems to be an important part of our everyday conception of the space in which material particles make their way

about (for example) that it is both homogeneous and isotropic.² It seems to be an important part of our everyday conception of the space in which material particles make their way about (that is) that it should be just as easy, in so far as the fundamental laws of physics are concerned, for a material particle to be in one location as it is for it to be in another, and that it should be just as easy, in so far as the fundamental laws of physics are concerned, for a material particle to be moving in one *direction* as it is for it to be moving in another. And the *two-dimensional* picture of the sort of world we are considering here obviously features a fundamental law that distinguishes between points *on* the diagonal and points *off* of it. But if you look at that same law in the context of the *one-dimensional* picture – if you look (that is) at the potential term in the Hamiltonian in the context of the one-dimensional picture - all it says is that the two particles can't *pass through* one another. And *that way* of putting it obviously makes no distinctions *whatever* between any two points in the one-dimensional space, or among either of its two directions.

Why couldn't we think of the presence potential barrier in the 2-dimensional picture (then) not as a matter of fundamental law, but (rather) as arising from the merely *de facto* configuration of a *field*? Well, *that* would amount to denying that the Hamiltonian in equation (3) is in fact the fundamental Hamiltonian of the universe.

² This could obviously do with some qualification. Aristotle (for example) famously thought otherwise. But there is an intuitive and well-known and long-standing classical-mechanical conception of space that I am gesturing at here, which I take it is recognizable to everyone, and which (with a little work) can be formulated in such a way as to apply to special and general relativity as well.

In that case (to put it in a slightly different way) the fundamental Hamiltonian of the world is going to be something more elaborate than the one in equation (3), something which offers a dynamical account not only the evolutions of the coordinates x_1 and x_2 , but the configurations of the *fields* as well (something, that is, that answers questions about how the fields *got* there, and how they *evolve*, how they are affected by changes in the x_1 and x_2 degrees of freedom, and so on). And that new fundamental theory is going to bring with it all sorts of new physical possibilities, and new counterfactual relations, that were not present in the original 2-dimensional Hamiltonian that we were dealing with above.

So, what feels more familiar about the first of these descriptions is that it features a space which is homogenous and isotropic, and which consists of the sorts of points at which ordinary material particles – particles (that is) which are associated with unique and determinate quantities of *mass* – might in principle be located. Let's refer to spaces like that (then) as spaces of *ordinary material bodies*. And note (since it will be important to what follows) that what is and isn't going to count, for this or that particular physical universe, as a space of ordinary material bodies, is not a matter of its fundamental metaphysical structure, but (rather) of its *dynamical laws*.

*

Good. Let's make things a little *more* complicated. Focus on the second of the two descriptions – the less familiar one, the 2-dimensional one - of the simple universe that we were talking about above. And now consider a *different* universe, a slightly more complicated one, which we obtain by introducing a *second* point-like physical item into the two-dimensional space – an item which we stipulate to be intrinsically identical to the first, and which floats around under the governance of exactly the same sort of Hamiltonian as the one in equation (3) (see figure 2). The complete Hamiltonian of a universe like that (then) is going to be:

$$H = (1/2m_1)(dx_1(t)/dt)^2 + (1/2m_2)(dx_2(t)/dt)^2 + (1/2m_3)(dx_3(t)/dt)^2 + (1/2m_4)(dx_4(t)/dt)^2 + \delta(x_1-x_2) + \delta(x_3-x_4) \quad (4)$$

where x_1 and x_2 are the λ and μ co-ordinates of item #1, and x_3 and x_4 are the λ and μ co-ordinates of item #2, respectively.

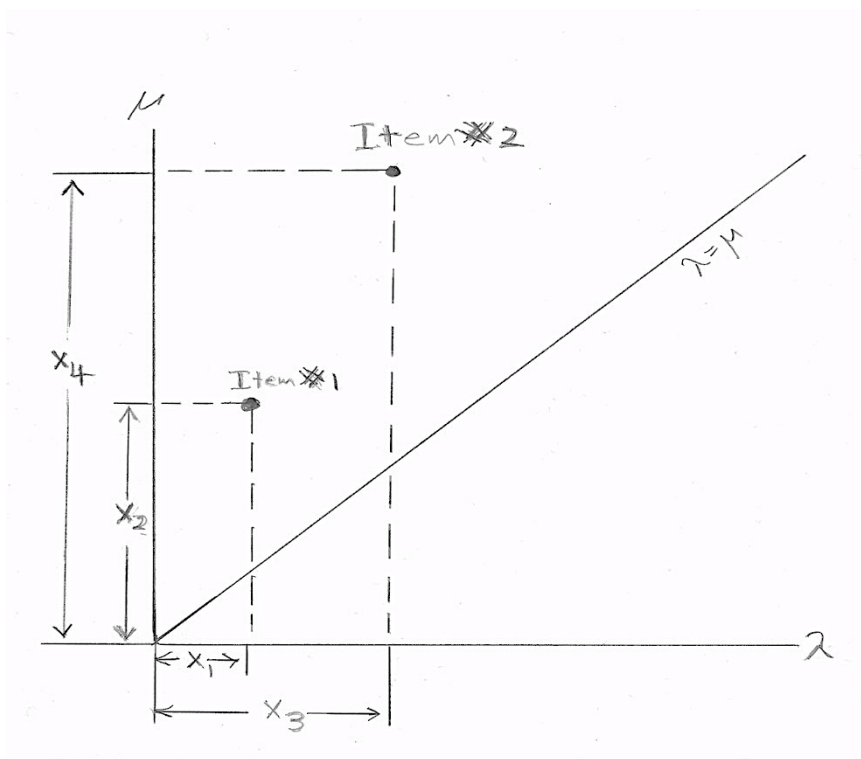

Figure 2

A universe like this one might be described as consisting of *four* ordinary material particles – call them particle 1 and particle 2 and particle 3 and particle 4 – moving around (as before) in a homogenous and isotropic *one*-dimensional space. x_1 will then represent the one-dimensional position of particle 1, and x_2 will represent the one-dimensional position of particle 2, and so on. But the *way* those particles move around is now going to be kind of funny. Suppose (just to keep things simple for the moment) that $m_1 = m_3$ and $m_2 = m_4$. Then particles 1 and 3 are going to be qualitatively *identical* to one another, and particles 2 and 4 are going to be qualitatively identical to one another, and yet the way that particle 1 *interacts*

with particle 2 is going to be *different* from the way that particle 3 interacts with particle 2, and the way that particle 2 interacts with particle 1 is going to be different from the way that particle 4 interacts with particle 1 (particle 1, for example, is going to bounce off of particle 2, but it will pass right through particle 4 – and particle 4 is going to bounce off of particle 3, but it will pass right through particle 1). And so, unlike in the two-particle case we considered before, a qualitative description of the physical situation of this world, at some particular time, in the one-dimensional space (that is: a complete specification of which four points in this one-dimensional space are occupied by particles, together with a specification of the *velocities* of the particles at each of those points, together with a specification of the *intrinsic properties* of the particles at each of those points) is *not* going to give us enough information to predict, even in principle, the qualitative situation of this world at other times.³

³ The first thing that's likely to pop into one's head, on being confronted with this, is that particle 1 must *not* (in fact) be qualitatively identical to particle 3, and (similarly) that particle 2 must not be qualitatively identical to particle 4. Let's think about how that might work. Suppose that particle 1 were *not* qualitatively identical with particle 3. Then there would have to be some pair of physical properties P and Q such one of them is P and the other is Q. And if particle 2 were not qualitatively identical to particle 4, then there would have to be some pair of properties R and S (which might or might not be different properties from the properties P and Q) such one of *them* is R and the other is S. And with these new properties in hand, one could of course write down a *law* – which would *account* for the motions of these particles - to the effect that (say) particles that are P only bounce off of particles that are R, and that particles that are Q only bounce off of particles that are S. Or something like that. But nothing like that can be right. What we are supposed to be imagining here (remember) is a universe that consists of two intrinsically identical point-like physical items, floating around in a two-dimensional space, in accord with the Hamiltonian in equation (4). What we are supposed to be imagining (to put it slightly differently) is that a specification of the locations of those two intrinsically identical point-like physical items in the two-dimensional space, at any particular time, amounts to a *complete* qualitative description of the world at the time in

Maybe the thing to say (then) is that the sort of world that we are imagining here is just not thoroughly *lawful* – maybe the thing to say (that is) is that there is simply not any fully general *rule* about how the complete physical conditions of a universe like this one at different times are *related* to one another. But that’s obviously not true! If we look back at the *two*-dimensional representation of this particular universe (after all) then everything immediately snaps into place: a complete specification of the qualitative situation, at any particular instant, in the *two*-dimensional space (that is) *is* going to give us enough information to predict, in

question – a description (that is) on which all of the other qualitative features of the world, at that instant, supervene. But if there are P’s and Q’s and R’s and S’s of the sort that we have just now been imagining – then (as the reader can easily confirm for herself) there are going to be *two* qualitatively *different* situations in the one-dimensional space corresponding to every pair of locations in the two-dimensional space – and so a specification of the locations of the two intrinsically identical point-like physical items in the two-dimensional space would *not* amount to a complete qualitative description of the world *after all*. And so – in the sort of world that we are imagining here, and if we are going to be in the business of attributing any physical properties *at all* to the particles that are moving around in the one-dimensional space – particle 1 *must* be intrinsically identical to particle 3, and particle 2 must be intrinsically identical to particle 4.

And even if we set aside the idea that these four material particles are “shadows” of something *else* moving around in a *higher*-dimensional space – even (that is) if we imagine a universe that consists of nothing whatever over and above those four material particles, moving around in a *one*-dimensional space, *as if* they were shadows of two identical point-like physical items moving around, in a two-dimensional space in accord with the Hamiltonian in equation (4) – it would still make no sense to imagine that particle 1 is somehow intrinsically different from particle 3, and that particle 2 is somehow intrinsically different from particle 4, because it follows from the qualitative identity of the two (imaginary) point-like physical items in the (imaginary) two-dimensional space that particle 1 is going to respond to any externally imposed force-field in exactly the way that particle 3 does, and that particle 2 is going to respond to any externally imposed force-field in exactly the way that particle 4 does.

principle, how that situation is going to evolve into the future. And from *that* (of course) we are going to be able to read off all of the future qualitative situations in the *one*-dimensional space as well.

In the case we considered before, the one-dimensional representation of the universe and the two-dimensional representation of the universe were straightforwardly *isomorphic* to one another. In the case we considered *before* (that is) there was exactly *one* possible state of the point-like item floating around in the *two*-dimensional space corresponding to every individual one of the possible states of the two *material particles* floating around in the *one*-dimensional space. But *here* (as shown in figure 3) there are *two* qualitatively different states of the two point-like physical items floating around in the two-dimensional space corresponding to every individual qualitative state the four material particles floating around in the *one*-dimensional space.

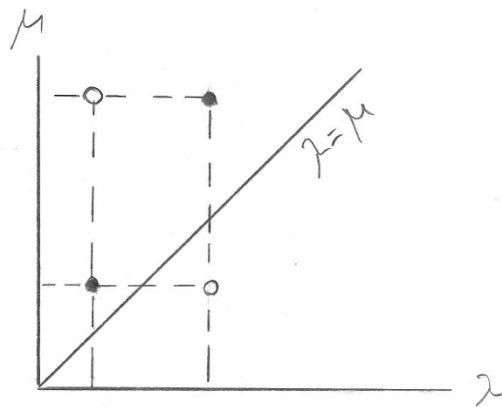

Figure 3: Two qualitatively different configurations of the pair of point-like items in the two-dimensional space (one of which is

represented by the two black dots, and the other by the two white ones) which are qualitatively identical in the one-dimensional space.

And so the *history* of the universe we are dealing with here – the history (that is) of this particular pair of point-like physical items floating around in this particular two-dimensional space - can simply not be *presented* in the form of a history of the motions of familiar material bodies, and the *dynamical laws* of a universe like the one we are dealing with here can simply not be *written down* in the form of *laws* of the motions of everyday material bodies. In the case we considered before (to put it slightly differently) the basic physical *stuff* of the world – the stuff on whose history the history of everything else *supervenies*, the stuff to which the *fundamental dynamical laws* apply - was the stuff of the *material particles*. But it seems like the right thing to say about a universe like *this* one is that the basic physical stuff is the stuff of the two *point-like items* in the *two-dimensional space* – and that the reason that everything looks so odd as viewed from the perspective of the *one-dimensional space* is that the *one-dimensional space isn't where things are really going on*, and that the *material particles that move around* in that space are really just “shadows” (as it were) of the actual, fundamental, physical items.

So there are going to be *two* sorts of space that are worth talking about in a universe like this one. There is, to begin with, the *one-dimensional habitation* of ordinary material bodies. And then there's the space in which one can *represent* everything that's going on, in which one can *keep track* of everything that's going on,

merely by saying what it is that's going on at every individual one of its *points* - the space (you might say) of *the totality of atomic opportunities for things, at any particular temporal instant, to be one way or another*. Call that "the space of the elementary physical determinables". And what we have just seen is that the space of the elementary physical determinables, in a world like the one we are dealing with here, has *two* dimensions.

The space of ordinary material bodies and the space of elementary physical determinables turn out to be very different kinds of things. It is part and parcel of our idea of the space of ordinary material bodies (for example) that all of the points in it are going to be intrinsically identical to one another – but the above example makes it clear that we should have no such expectations, as a general matter, about the space of elementary physical determinables. The space of ordinary material things is the set of points at which you could imagine, in principle, placing the tip of your finger. But the items that move around in the space of the elementary physical determinables, at least in the case of the sort of universe we are considering now, are not material bodies at all.

But (notwithstanding all that) the space of the elementary physical determinables is clearly the more *fundamental* of the two. The situation in the space of ordinary material bodies (once again) *supervenies*, by *definition*, on the situation in the space of the elementary physical determinables – but the reverse is of course not true – or not (at any rate) in the sort of world we are thinking of here. So the

sorts of distinctions that one can make in the language of the space of the elementary physical determinables are more *fine-grained* than the sorts of distinctions one can make in the language of the space of ordinary material bodies. Moreover, the space of the elementary physical determinables is what fixes the *elementary kinematical possibilities* of the world – and so it is (in that sense) something logically *prior* to the laws of dynamics, it's something like the *arena* within which those laws *act*. But the space of *ordinary material things* (as I mentioned before) is something whose topology and whose geometry and whose very *existence* all explicitly *depend* on what the fundamental dynamical laws actually happen to *be* – it's something that the dynamics can be thought of as *producing*, something which is (in that sense) *emergent*.

There are other differences too – there is an interesting question (for example) about whether the space of the elementary physical determinables needs to be thought of as *having* any geometry *at all* – but a discussion of those would take us too far afield at the moment.⁴

The image of 'space' that all of us grew up with (then) turns out to be a crude and undifferentiated amalgam of *both* a space of ordinary material bodies and a space of elementary physical determinables. That physics should never heretofore have taken note of the distinction *between* these two sorts of spaces is entirely unsurprising – because they happen to be *identical* with one another (just as they

⁴ These issues of the origin and significance of distance are the focus of a recent unpublished manuscript of mine called "On the Emergence of Space and Time".

were in the two-particle, one-dimensional example we considered above) in Newtonian Mechanics, and in Maxwellian Electrodynamics, and in the physics of everyday macroscopic practical life. The manifest image of the world (you might say) includes *both* a space of ordinary material things *and* a space of the elementary physical determinables - together with the stipulation that they are, in fact, *exactly the same thing*. And classical physics never gave us any reason to imagine otherwise. But (notwithstanding all that) these two ideas would seem to be worth carefully prying apart. They have nothing *logically* to do with one another, and it is the easiest thing in the world (as we have just seen) to imagine universes, and to write down Hamiltonians, in which (for example) they have different numbers of dimensions.

Ok. Let's get back, with all this in mind, to the particular system we were thinking about before - the one described by the Hamiltonian in equation (4). One of the effects of introducing a second point-like physical item into the two-dimensional space is (as we have seen) to *pry apart* the space of ordinary material bodies and the space of elementary physical determinables - to make them (in particular) into two distinct and topologically different spaces. And one of the effects of this coming-apart is that the goings-on in the space of ordinary material bodies - or (rather) that the goings-on in the *physical universe*, as *viewed* from the *perspective* of the space of ordinary material bodies - begins to look odd.

Particles 1 and 2 bounce off one another, and particles 3 and 4 bounce off one another, but (even though particle 1 is intrinsically identical to particle 3 and particle 2 is intrinsically identical to particle 4) the particles 1 and 2 move around as if particles 3 and 4 simply did not exist, and particles 3 and 4 move around as if particles 1 and 2 simply did not exist. And so what we are presented with, in the space of the ordinary material bodies of a universe like this one, is less like a collection of *four* particles floating around in a one-dimensional space, than it is (say) like a pair of causally unconnected parallel *worlds*, in each of which there is a pair of particles is floating around in a one-dimensional space, or like a pair of different *possibilities*, or like a pair of different *scenarios*, about how *one and the same* pair particles *might* be floating around in a one-dimensional space, or something like that. Whatever is true in *both* of the scenarios is apparently true *simpliciter* – so that (for example) if x_1 and x_3 both happen to be equal to 5, then the first particle (the one whose mass is $m_1 = m_3$) is unambiguously located at point 5 in the one-dimensional space of ordinary material bodies – but it's harder to know exactly what to say about facts on which they differ.

If we were adamant about representing a universe like this to ourselves in its one-dimensional space of ordinary material bodies, we might do so with the help of an additional piece of notation – a pair of brackets (say), one of which links particle 1 with particle 2, and the other of which links particle 3 with particle 4 - as in figure 4 – to indicate which particles share these 'scenarios' with one another and which

don't.

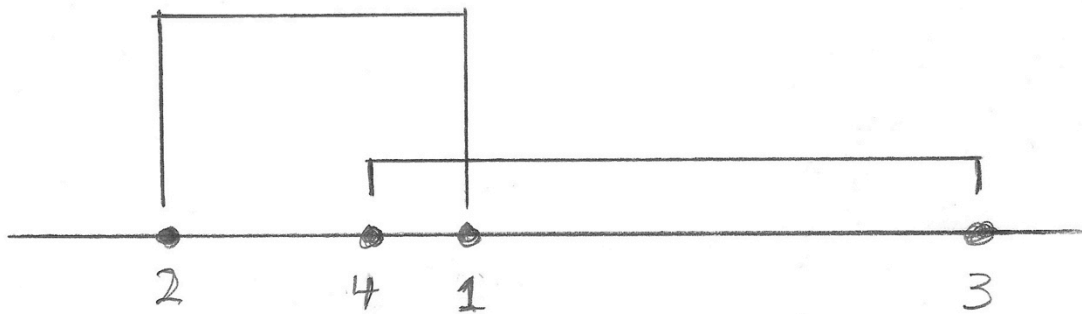

Figure 4

From the point of view of the *two-dimensional space of elementary physical determinables*, the brackets are just a way of keeping track of the connections between the four ordinary material particles in the one-dimensional space and the two point-like physical items in the two-dimensional space. But if we are resolute in banishing any thought of that latter space from our minds, then we are apparently going to need to think of the brackets as signifying some real and radically unfamiliar and not-further-analyzable physical connection between pairs of material particles *themselves* – something that can not be *reduced* to, something that does not *supervene* on, the spatial distribution of local physical properties.

*

Ok. Let's complicate things *still* more. Suppose that we were to add a term of the form $\delta(x_1-x_2)\delta(x_3-x_4)$ to the Hamiltonian in equation (4), so that it looks like this:

$$H = (1/2m_1)(dx_1(t)/dt)^2 + (1/2m_2)(dx_2(t)/dt)^2 + (1/2m_3)(dx_3(t)/dt)^2 + (1/2m_4)(dx_4(t)/dt)^2 + \delta(x_1-x_2) + \delta(x_3-x_4) + \delta(x_1-x_3)\delta(x_2-x_4) \quad (5)$$

That would amount to adding a new and funny kind of an interaction - an interaction not between two of the *particles* floating around in the *material* space, but (rather) between the two point-like *items* floating around in the *determinable* space - an interaction (that is) between what might previously have looked to us, from the perspective of the *material* space, like two different *possibilities*, or two different *scenarios*, or two distinct and parallel *worlds*.

Note (to begin with) that this new term is still going to preserve the invariance of the Hamiltonian under translations in the one-dimensional space - and so the material space of this new world, the space in which all points are intrinsically identical, the space in which particles have unique determinate masses, is still going to be one-dimensional. But the *behaviors* of these particles, as viewed from the one-dimensional space in which they live, are getting odder and odder.

The effect of adding this new interaction is going to be quantitatively small - because collisions between the two point-like items in the determinable space are going to be much much rarer than collisions between either one of them and the

fixed diagonal potential barrier - but it is nonetheless going to be conceptually profound. From the perspective of the material space things are still going to look more or less as if there are two pairs of particles floating around in two parallel possible situations – linked together by their mysterious brackets. But a more detailed examination is now going to reveal that this picture of parallel possible situations does not quite hold up – because the evolutions of these two possibilities can sometimes, in fact, *interfere* with one another.

Moreover, the effects of this new interaction, as viewed from the perspective of the space of ordinary material bodies, are going to be bizarrely *non-local*. Particles 1 and 3 are going to collide with one another (that is: particles 1 and 3 are going to *interact* with one another, particles 1 and 3 are suddenly going to become *visible* to one another, particles 1 and 3 are suddenly going to be unable to *pass through* one another) *only* in the event that particles 2 and 4 happen to be colliding with one another, somewhere in the material space, *anywhere* in the material space, at exactly the same temporal instant. And vice versa. And the mechanism whereby those two collisions make one another possible does not depend on any way whatever on the one-dimensional physical distance *between* them – it only depends on their primitive and unanalyzable and now even more mysterious bracket-connections.

And all of this should by now have begun to remind you of quantum mechanics. But the business of saying exactly *how* it should remind you of quantum mechanics – the business of saying exactly *what* should remind you of *what* - requires close

attention. The thing that needs to be kept in mind, the thing that people seem to have trouble taking in when all of this is first presented to them, is that introducing another point-like concrete fundamental physical item to the 2-dimensional space is *not at all* like introducing another *particle* to the 1-dimensional space, or like introducing another *pair* of particles to the 1-dimensional space, or like introducing a second Bohmian Marvelous Point into the contents of the sort of universe that we have been thinking about here - but (rather) like adding another *term*, like adding another *branch*, to the quantum-mechanical *wave-function* of the *single, original, two-particle system* in the 1-dimensional space. Consider, for example, a pair of quantum-mechanical particles, one of which (particle 1) has only position-space degrees of freedom, and the other of which (particle 2) has both spin *and* position-space degrees of freedom. And suppose that the quantum state of that pair of particles, at a certain time, is:

$$(1/\sqrt{2})[x=\alpha>_1[x=\gamma, \uparrow_z>_2 + (1/\sqrt{2})[x=\beta>_1[x=\gamma, \downarrow_z>_2 \quad (6)$$

And note that if $\alpha \neq \beta$ (which is to say: if the two versions of particle 1 do not happen to be located at the same point in space) then the reduced density matrix of particle 2 is going to be an incoherent mixture of spin-states – but if $\alpha = \beta$ (which is to say: if the two versions of particle 1 *do* happen to be located at the same point in space) *then* the two spin-states of particle 2 are going to *interfere* with one another, in such a way as to produce an eigenstate of *x*-spin. And note (as well) that none of this

depends in any way on how far apart in space α (or β) and γ may happen to be, or what may happen to be going on in the space between them.⁵

*

Let's go one step further. This one (however) will take a bit of setting up.

To begin with, replace the very sharply peaked potential barrier along the diagonal in the two-dimensional space with a more smoothly varying potential *well* along the diagonal in the two-dimensional space. That is: replace the $\delta(x_1-x_2) + \delta(x_3-x_4)$ in (4) with $V(|x_1-x_2|) + V(|x_3-x_4|)$, where $V(|r|)$ is some smoothly varying and monotonically increasing function of $|r|$ which, and which is negative for all finite values of $|r|$, and which asymptotically approaches zero as $|r|$ approaches infinity. This amounts to replacing the sharp contact repulsive force between particles 1 and 2 and particles 3 and 4 in the one-dimensional space with a force that *attracts* 1 *towards* 2 and 3 *towards* 4, and which acts across finite distances (like Newtonian gravitation, say) in the one-dimensional space. And let's stipulate, as well, that this attractive force can be switched on and off as we wish.

⁵ The reader might like to consider why it is that the kind of quantum-mechanical non-locality on display in this example cannot be exploited, as a matter of fundamental principle, for the superluminal transmission of information. There is, of course, a famous argument, due to Von Neumann, to the effect that the non-localities associated with the *collapse of the wave-function*, or with the *effective* collapse of the wave-function, cannot be exploited for the superluminal transmission of information – but there are no collapses here, and the sort of argument one needs in a case like this turns out to be somewhat different.

The Hamiltonian we're dealing with now (then) is

$$H = (1/2m_1)(dx_1(t)/dt)^2 + (1/2m_2)(dx_2(t)/dt)^2 + (1/2m_3)(dx_3(t)/dt)^2 + (1/2m_4)(dx_4(t)/dt)^2 + g(t)(V(|x_1-x_2|) + V(|x_3-x_4|)) + \delta(x_1-x_3)\delta(x_2-x_4) \quad (7)$$

where the $g(t)$ is there simply to remind us that we are allowed to switch that part of the potential energy on and off at our discretion.

And note (yet again) that none of these changes are going to alter the fact that the *material* space of a system like this is the one-dimensional space, and that its *determinable* space is the *two*-dimensional one.

Good. Now suppose (for reasons that will presently become clear) that particles 1 and 3 are much more massive than particles 2 and 4. And set things up as follows: The attractive force is off, and particles 2 and 4 are at rest at the origin, and particle 1 is at the point +1 and particle 3 is at the point -1, as depicted in figure 5.



Figure 5

The corresponding arrangement in the *two-dimensional* space, which is depicted in figure 6, has one of the point-like physical items - item number 1 - at the point $(\lambda=+1, \mu=0)$ and the other - item number 2 - at $(\lambda=-1, \mu=0)$. The small arrows in figures 5 and 6 indicate the directions in which the two particles (in the case of figure 5) and the two point-like items (in the case of figure 6) will begin to move once the attractive potential is switched on.

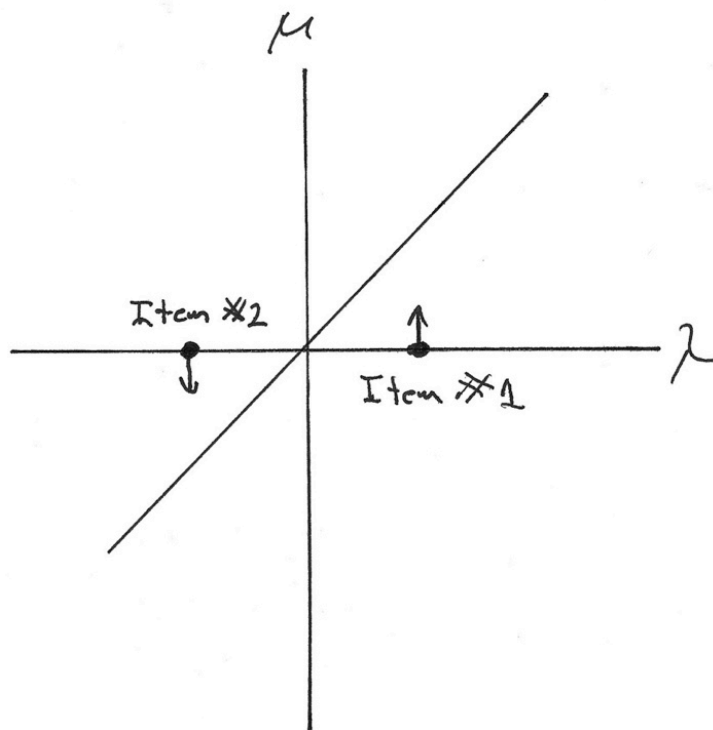

Figure 6

Since particles 2 and 4 are *touching* one another here, particles 1 and 3 are going *bounce off* one another if they should happen to meet. So particles 1 and 3, in *this* situation, do *not* relate to one another much like components of two distinct *possibilities*, or of two *parallel worlds*. Indeed - and on the contrary - what we are

dealing with here (so long as the y-particles remain at rest, and touching one another, and so long as the attractive forces are switched off) is just the familiar case of two particles (the x-particles) moving around in a one-dimensional space, and interacting with one another by means of a repulsive contact interaction – precisely the case (that is) that we started off with.

And now suppose that we switch the attractive forces on. At this point we will have moved things into a regime in which *both* of the dimensions of the determinable space associated with the Hamiltonian in (7) come decisively into play. And one way to think about what's going *on* here is that we have switched on a pair of *measuring-devices* for the positions of particles 1 and 3 – devices whose *pointers* are particles 2 and 4. When the attractive forces are switched on, each of the y-particles starts to move in the direction of its corresponding x-particle – each of the y-particles *indicates* (you might say) the direction in which its corresponding x-particle is *located* – and it was precisely in order to build the appropriate sort of asymmetry into this indicator-indicated relationship that we stipulated, a few paragraphs back, that the masses of particles 1 and 3 be much larger than the masses of particles 2 and 4.

And note (and this is the punch line) that as soon as these measurements take place, and for as long as their different outcomes are preserved in differences between the positions of particles 2 and 4, the whole metaphysical character of the situation – at least as viewed from the 1-dimensional material space - appears to

radically shift. Any possibility of interaction between particles 1 and 3 is now abolished, and the system behaves, again, for all the world, as if it were a pair of mutually exclusive *scenarios*, or of *parallel universes*, in one of which a light particle detects a heavy particle at position +1, and in the *other* of which the *same* light particle detects the *same* heavy particle, instead, at position -1. And anyone familiar with (say) the *many-worlds* interpretation of quantum mechanics, or with the *decoherent histories* interpretation of quantum mechanics, is going to recognize that what we have stumbled across here is precisely the annihilation of the off-diagonal *interference* terms, in the reduced density matrix of a measured system, by the interaction with a *measuring-device* - and anyone familiar with *Bohmian Mechanics* is going to recognize that what we have stumbled across here is precisely the phenomenon that is responsible for the so-called effective collapse of the wave-function.

There is, of course, as yet, no unique determinate fact of the matter about the *outcome* of the sort of measurement described above. What we are left with - once the attractive potential is switched off - is (again) something like a pair of parallel universes, in one of which a light particle has detected a heavy particle at position +1, and in the *other* of which the *same* light particle has detected the *same* heavy particle, instead, at position -1. And the business of arranging for one or the other of those universes to somehow amount to the *actual* one is just the familiar business of solving the quantum-mechanical problem of *measurement*: You either find a way of making one or the other of those universes *disappear* (that's the sort of thing that

happens in theories of the “collapse of the wave-function”) or you find a way of endowing one or the other of those universes with some sort of special *status* (as one does, for example, in Bohmain Mechanics). But we are getting ahead of ourselves. Put the measurement problem to one side for the moment – we’ll come back to it later.

*

We can edge still closer to the familiar quantum-mechanical formalism by replacing the point-like physical items in the space of elementary physical determinables by something more like *fields*. In the examples we considered above, in which different possible situations in the space of ordinary material bodies corresponded to different concrete point-like physical items floating around in the space of elementary physical detirminables, the business of arranging for the possibility of *interference* between different such situations had to do with the introduction of new terms into the fundamental Hamiltonian of the world – terms (for example) like the $\delta(x_1-x_3)\delta(x_2-x_4)$ in equations (5) and (7) - whereby the different point-like physical items can literally *push* or *pull* on one another. But fields can do something *else* to one another, something that has *nothing to do* with pushing or pulling, something that doesn’t depend on the introduction of any additional *terms* into the *Hamiltonian*: they can *add to* or *subtract from* one another - they can *interfere* (that is) in the way that *water* waves do. So if what we think of as inhabiting the space of elementary physical detirminables are something like *fields*,

then something like a principle of superposition – then (that is) the possibility of various different possible situations in the space of ordinary material bodies actually physically *interfering* with one another - is going to be built right into the fundamental *kinematics* of the world, just as it is in quantum mechanics, and it's not going to require any specialized additions to the laws of dynamics.

Here's a very simple example.

Go back to case of a single point-like physical item, floating around in a two-dimensional space, with a diagonal potential barrier. And imagine that we replace that item with a scalar field – a field which always has the value +1 at exactly one of the points in the 2-dimensional space, and which always has the value zero everywhere else. And suppose that the point at which the field has the value +1 moves around in the 2-dimensional space – just as the point-like physical system did in the earlier example – in accord with the Hamiltonian in equation (3).

It will be natural – just as it was in the case of the single point-like item floating around in a 2-dimensional space, and for exactly the same *reasons* as it was in the case of the single point-like item floating around in the 2-dimensional space – to describe a world like this as consisting of a pair of ordinary material particles, of different masses, floating around in a homogenous and isotropic 1-dimensional space.

Suppose now that there are *two* points in the 2-dimensional space at which the field is non-zero, and suppose (just to make things interesting) that the field has the value +1 at one of those points and that it has the value -1 at the other, and suppose that the two points in question move around the 2-dimensional space in accord with the Hamiltonian in equation (4). A universe like this one can be described (as before) as consisting of *four* ordinary material particles, moving around in a homogenous and isotropic one-dimensional space. But the *way* those particles move is (again) going to be kind of funny. If $m_1 = m_3$, and if $m_2 = m_4$, and if we assume that signs of the fields in the 2-dimensional space can make no difference to the intrinsic properties of their one-dimensional shadows, then particle 1 and particle 3 are going to be intrinsically *identical* to one another - and yet particle 1 is going to *elastically collide* with particle 2, whereas particle 3 is going to *pass right through* particle 2, and so on. And so (again) a qualitative description of the physical situation at some particular time, in the one-dimensional space, is *not* going to give us enough information to predict, even in principle, the qualitative situation of this world at other times. And so the 2-dimensional space of elementary physical determinables turns out (again) to be more fundamental - in all of the ways that we have already discussed - than the one-dimensional space of ordinary material bodies. And so (again) this turns out to be less like a collection of *four* particles floating around in a one-dimensional physical space than it is like two different *possibilities* about how *two* such particles might be floating around in a one-dimensional space, or like two causally unconnected parallel *worlds*, in each of

which a pair of particles is floating around in a one-dimensional space, or something like that.

Except that here – even in the absence of any further modification of the fundamental laws of motion which is designed to allow these two possibilities to *dynamically interact* with one another, even in the absence (that is) of an additional term in the Hamiltonian like the $\delta(x_1-x_3)\delta(x_2-x_4)$ of equations (5) and (7) – they can nevertheless, now and then, and in an altogether different and purely kinematical way, *interfere* with one another. Note (for example) that if the two field-points in the two-dimensional space of elementary physical determinables should ever happen to cross paths, their two fields will *cancel* one another. And what that means is that if (for example) the positions of particles 2 and 4 in the *one-dimensional space of ordinary material bodies* should ever happen to *coincide*, and if (while the positions of 2 and 4 coincide) particles 1 and 3 should ever happen to come together, then, no matter how far apart particles 1 and 3 may happen to be from particles 2 and 4, *all four of the particles are going to disappear!* This is not the kind of thing (of course) that can happen to non-relativistic *quantum-mechanical* particles. It would amount (for one thing) to a violation of unitarity. But it is – for all that, and in all sorts interesting respects - not very far from cases of thoroughly quantum-mechanical interference like the one described in equation (6). And a few obvious further modifications will get us - as literally as you please - all the way there.

*

Let's start by allowing the field to be non-zero at any number (that is: any *finite* number, or any countably *infinite* number, or any *uncountably* infinite number, or even the entire collection) of points in the space of elementary physical determinables. The different possible physical states of the world (then) will consist of the different possible *configurations* of the *field* – the different possible states of the world (that is) will consist of different possible assignments of field-values to every one of the continuous infinity of points in the space of the elementary physical determinables. And let's suppose that the field $F(\lambda, \mu)$, at any point (λ, μ) in the space of elementary physical determinables, can take on *complex* values, and let's suppose that there is a law (or perhaps an initial condition) to the effect that the integral of $|F(\lambda, \mu)|^2$, over the entirety of the two-dimensional space of determinables, at any particular temporal instant, is equal to 1.

Now, every function of λ and μ that obeys the above stipulations can – as a matter of pure mathematics - be represented as a unique vector, of length 1, in an infinite-dimensional Hilbert space. And we can define – in the familiar way - an inner product on that space. And with that mathematical apparatus in hand, we can stipulate that the evolution of the vector that represents the field-configuration of the world in time is given by some deterministic and linear and unitary time-translation operator whose infinitesimal generator is a Hermetian operator on that space called (by analogy with its classical counterpart) a Hamiltonian.

And now, at last, what we have in front of us, in all its glory, is what is usually referred to as the *Quantum Theory* of a pair of non-relativistic structureless spin-zero particles, floating around, and interacting with one another, in a one-dimensional “physical space”. But what that theory actually appears to be *about*, if you come at it by way of the simple and mechanical and flat-footed route that we have been following here, is a *field*. And the space of points on which that field is *defined*, the space of points at which that field takes on *values*, has *two* dimensions rather than one. And all of the familiar talk of *particles* floating around in a *one*-dimensional space has to do with the way things look from the point of view of the space of *ordinary material bodies* – which (again) is something *other*, and *smaller*, *less fundamental* than the stage on which the full history of the world plays itself out, and which emerges as a by-product of the action of the Hamiltonian.

*

This picture of the wave-function as concrete physical *stuff* may seem hard to fit together, at first, with what one thinks one knows about quantum mechanics. Consider (for example) the question of *observables*. We are told – in standard presentations of quantum mechanics - that no measurement can distinguish, with certainty, between a system in the state $F(q_1 \dots q_N)$ a system in the state $F'(q_1 \dots q_N)$ unless the vectors representing $F(q_1 \dots q_N)$ and $F'(q_1 \dots q_N)$ happen to be *orthogonal* to one another. But why in the world – on this new way of thinking - should anything

like that be the case? If these $F(q_1\dots q_N)$'s are really concrete physical *stuff* – as opposed to abstract mathematical descriptions of the states of something *else* - why is it that anything should stand in the way of our measuring the *amplitude* of that stuff, to any accuracy we like, at any point we please, just as we routinely do with (say) *electromagnetic* fields?

Let's see.

The crucial point (it turns out) is that the very *idea* of measurement is inextricably bound up with the space of *ordinary material things*. The point (more precisely) is that in order for this or that physical quantity to count as something *measurable*, there must be possible physical processes whereby the value of that quantity can reliably be brought into correlation with the positions of *ordinary material objects* (the positions of pointers, the distributions of ink-molecules on pieces of paper, etc.) in the space of *ordinary material things*.

Let's start with a simple paradigm case - from which (thereafter) the reader can easily generalize, as much as she pleases, for herself.

Suppose (then) that the symmetries of the Hamiltonian of the world entail that the space of ordinary material bodies happens to be 1-dimensional, as in the examples that we were considering above. And divide the q_i into three disjoint sets: the 'pointer' set $\{q_1\}$, and the 'object' set $\{q_2\dots q_0\}$, and the 'rest-of-the-world' set

$\{q_{0+1} \dots q_N\}$. And posit a single very simple connection – a single very simple *rule of correspondence* - between the field-configuration in the space of elementary physical determinables and our everyday empirical experience of the world, to wit: the ‘pointer’ particle is at or around position x in the space of ordinary material things if and only if $F(q_1 \dots q_N)$ vanishes, or almost vanishes, outside of the region bounded by $(q_1 = x - \epsilon)$ and $(q_1 = x + \epsilon)$, where ϵ is small.⁶ That (it turns out) will be all we need.

Now, two different field-configurations of the ‘object’, $f(q_2 \dots q_0)$ and $f'(q_2 \dots q_0)$, can be distinguished from one another by a measurement if and only if there is at least one possible field-configuration of the ‘pointer+rest-of-the-world’ – call it $g(q_1, q_{0+1} \dots q_N)$ - such that if the field-configuration of the world at t_0 is $g(q_1, q_{0+1} \dots q_N)$ $f(q_2 \dots q_0)$, then the pointer particle ends up, at a certain later time t_1 , at the point x , and if the field-configuration of the world at t_0 is $g(q_1, q_{0+1} \dots q_N)$ $f'(q_2 \dots q_0)$, then the pointer particle ends up, at that same later time t_1 , at the point y , where the distance between x and y is much greater than ϵ .⁷

⁶ The thought here harks back to our discussion of the system described by the classical Hamiltonian in equation (4). The thought (that is) is that the ‘pointer’ particle is at or around x if and only if all of what we were previously calling the ‘scenarios’ combined in $F(q_1 \dots q_N)$, or *almost* all of them, or almost all of an appropriately weighted *combination* of them, *agree* that it is.

This particular rule of correspondence (by the way) will be appropriate to versions of quantum mechanics – like the GRW theory - whose fundamental ontologies consist *exclusively* of the fields $F(q_1 \dots q_N)$. For theories like Bohmian Mechanics – which have richer fundamental ontologies – a different rule will be appropriate. But the reader who is familiar with Bohmian Mechanics will have no trouble in confirming for herself that an argument very much analogous to the one that follows, and which arrives, in the end, at exactly the same conclusion, can be constructed in that theory as well.

⁷ The “if” here is just a matter of reflecting on what it *means* to distinguish between two situations by means of a measurement – but the “only if” requires a somewhat

And it follows from the above correspondence rule that any $F(q_1 \dots q_N)$ in which the pointer particle is located at x is orthogonal (or nearly so) to any $F(q_1 \dots q_N)$ in which the pointer particle is located at y . And so it will follow from the above analysis of what it is to be able to distinguish between $f(q_2 \dots q_0)$ and $f'(q_2 \dots q_0)$ by means of a measurement, and from the stipulation the universal operator of time-translation is unitary, that $f(q_2 \dots q_0)$ and $f'(q_2 \dots q_0)$ can only be distinguished from one another by means of a measurement if *they* are orthogonal to one another. And it will follow from *that* that if $f(q_2 \dots q_0)$ and $f'(q_2 \dots q_0)$ can be distinguished from one another by means of a measurement, then there must be some Hermetian operator of which both $f(q_2 \dots q_0)$ and $f'(q_2 \dots q_0)$ are eigenfunctions, with different eigenvalues.

And from there, without too much further trouble, one can recover the entirety of the algebra of the quantum-mechanical observables.

2

Here's what's happened so far:

more elaborate argument. The interested reader can find such an argument on pages 89-91 of a recent book of mine called *After Physics*.

We started off by looking at two ways of representing a classical system with two dynamical degrees of freedom, whose Hamiltonian consists of the standard kinetic energy terms and a simple contact interaction. One of these represents the system as a pair of particles floating around in a one-dimensional space of ordinary material bodies, and the other represents the system by means of a single point-like physical item in the two-dimensional space – the space of the possible *one-dimensional configurations* of the pair of particles floating around in the space of ordinary material bodies. Because these two ways of representing the system are both complete, and because they are fully mathematically equivalent to one another, and because the two-dimensional representation looks (in all sorts of ways) less natural, and less familiar, and less like the manifest image of the world than the one-dimensional representation does, there seemed to be no compelling reason to take the two-dimensional space philosophically seriously.

But as soon as we imagine an *additional* point-like physical item floating around in the two-dimensional space, all of this abruptly changes. Once the two-dimensional space is inhabited by more than a single such item, the one-dimensional representation and the two-dimensional representation are no longer mathematically equivalent to one another – and *each* of them seems to have a distinct and philosophically interesting role to play. The one-dimensional space is still the space of ordinary material bodies – but the representation of the system in that space is no longer mathematically complete. And the smallest space in which

the system can be represented in a complete and separable way⁸ – the space (that is) of the elementary physical determinables - is now *two*-dimensional.

Moreover, the general *direction* of these changes is unmistakably *quantum-mechanical*. It turns out that adding another concrete point-like fundamental physical item to the higher-dimensional space is not so much like adding more *concrete physical material* to the lower-dimensional space as it is like adding another low-dimensional *world*, or another actualized low-dimensional *possibility*, or another *term* in a quantum-mechanical *superposition*. And these different possibilities can be made to *interact* with one another, in ways that are very much reminiscent of quantum-mechanical *interference*, by means of the addition of another very simple term to the Hamiltonian. And the addition of such a term also generates distinctly quantum-mechanical sorts of non-locality, and distinctly quantum-mechanical images of measurement, and so on.

And (on top of that) it happens to be a characteristic of *classical* physical theories that the space of ordinary material things and the space of elementary physical determinables are exactly and invariably *one and the same*. And it seems natural to wonder whether all of this points to some kind of a *diagnosis*, or some kind of an *explanation*, of the actual un-classical weirdness of the world. It seems natural to wonder (that is) whether it is precisely this coming-apart of the space of ordinary

⁸ What it means for a representation to be *separable*, by the way, is for that representation to take the form of a spatial distribution of local physical properties. What it means (that is) for a representation to be separable, in the language I introduced a few pages back, is for it not to involve any *entanglement*.

material things and the space of elementary physical determinables that turns out to be at the bottom of everything that's exceedingly and paradigmatically *strange* about quantum mechanics.

But how can that possibly be true? For quantum-mechanical systems consisting of just a single structureless spin-zero particle (after all) the space of ordinary material bodies and the space of elementary physical determinables are precisely one and the same, just as they are for classical systems. And yet a hell of a lot of what everybody agrees is exceedingly and paradigmatically strange about quantum mechanics can already be encountered in systems like that.⁹ And this will be worth thinking through in some detail. And the business of thinking it through will be the work of this section.

Consider (then) a single structureless particle, in a 3-dimensional space of ordinary material things, whose quantum-mechanical wave-function happens to be non-zero, at a certain particular time, in two separate and compact and disjoint regions of that space called A and B.

What's strange about situations like that is that both of the following claims about the particle in question are apparently, simultaneously, true:

⁹ Feynman famously says (for example) that the *only* mystery in quantum mechanics is the one that comes up in connection with the double-slit experiment – and the double-slit experiment seems (on the face of it) to involve nothing over and above a single structureless particle moving around in the presence of a complicated (double-slitted) external potential.

- 1) There is a perfectly concrete and observable sense in which the particle, or something very closely associated with the particle, is in *both* regions. (What I have in mind here, when I speak of a 'concrete and observable' sense in which the particle is in both regions, is of course the possibility of measuring the effects of *interference* between the branch of the wave-function that's located in A and the branch of the wave-function that's located in B – as, for example, in the double-slit experiment)
- 2) There is a perfectly concrete and observable sense in which the particle, and everything sufficiently closely associated with the particle, is in only *one* of those regions. (And what I have in mind here, when I speak of a 'concrete and observable' sense in which the particle is in only one region, is the fact that if we measure the particle's spatial location, we will either find a particle in A and nothing whatever in B, or we will find a particle in B and nothing whatever in A)

Note (to begin with) that there is nothing particularly unintelligible, in and of itself, about claim (1). (1) is what Bohr and his circle used to call the 'wave' aspect of quantum-mechanical particles – and one could think of that, in the absence of (2), as suggesting a novel but by no means unfathomable picture of the subatomic structure of matter, according to which particles are to be understood, at the

microscopic level, as something akin to *clouds* or *fluids* or *fields* that can (in certain circumstances) spread themselves out over finite and even disjoint regions of the space of ordinary material things.

What has always completely *freaked everybody out* (on the other hand) is the combination of (1) *and* (2). And it turns out that all of the ways that we have of imagining that (1) and (2) could (somehow) *both* be true are going to involve telling stories about systems that consist of *more* than a single particle, systems (that is) whose quantum-mechanical wave-functions take on values at points in spaces of more than 3 dimensions, systems (that is) for which the space of elementary physical determinables *diverges* from the space of ordinary material things.

Let me try to say, a little more concretely, what I have in mind.

Note (to begin with) that the business of figuring out how (1) and (2) could both be true is nothing other than the business of solving the quantum-mechanical measurement problem. And so the various attempts at coming to terms with (1) and (2) together that we ought to have in the back of our minds here are things like the GRW theory, and Bohmian Mechanics, and the Many-Worlds interpretation. And it turns out that all of those attempts, and all of the strategies that anybody has ever so much as hinted at for solving the quantum-mechanical measurement problem, depend on the phenomenon of *entanglement*. And the phenomenon of entanglement is, as we have noted before, and as a straightforward matter of

definition, the phenomenon of the divergence of the space of elementary physical determinables from the space of ordinary material things.

Consider (for example) the case of Bohmian Mechanics. The phenomena that pertain to (1) have to do – in the context of Bohmian Mechanics – with the fact that the wave-function of the sort of particle we were describing above is non-zero both in region A and in region B. And it might look, at first glance, as if the business of accounting for the phenomena that pertain to (2), in the context of Bohmian Mechanics, amounts to nothing more than the simple observation that – notwithstanding that the wave-function of this particle is spread over both region A and region B – the Bohmian corpuscle itself is located either in region A or in region B. And all of that can of course be presented in the form of a story about what things are physically like, at various different times, at various different points in the familiar 3-dimensional Euclidian space of ordinary material things, and of our everyday empirical experience of the world.

But this (on a little reflection) is all wrong. What (2) is about is not merely that the particle *is* either in region A or in region B, but (in addition) that when we *look* for the particle we *see* it either in region A or in region B, and (moreover) that what we see is in fact reliably correlated with where the particle actually *is*, and that what we see matches up in the appropriate way with what we would see if we were to look *again*, and with what somebody *else* would see if they were to look for *themselves*, and with how the particle itself will behave in the future, and so on. And if

not for all that, there would (indeed) be nothing here to puzzle over. And the various businesses of accounting for all that, in the context of Bohmian Mechanics, all depend (again) on the fact that the process of measurement invariably and ineluctably generates quantum-mechanical entanglements between the measuring-devices and the measured particle.¹⁰

¹⁰ Maybe it will be worth taking a minute to rub this in.

Suppose that the initial wave-function of the composite system consisting of a particle (p) and a measuring-device (d), which is designed to record the position of that particle, is:

$$[\text{ready}]_d(\alpha[A]_p + \beta[B]_p), \quad (\text{i})$$

where $[\text{ready}]_d$ is the physical state of the system d in which d is plugged in and properly calibrated and facing in the right direction and in all other respects ready to carry out the measurement of the position of p , and $[A]_p$ is the state of p in which p is localized in the spatial region A , and $[B]_p$ is the state of p in which p is localized in the spatial region B .

And note, to begin with, that any satisfactory scientific account of why it is that if we measure the position of a particle like this 'we will either find a particle in A and nothing whatever in B , or a particle in B and nothing whatever in A ' has got to be an account not only of the behavior of p under circumstances like (i), but also of the behavior of d under circumstances like (i).

Good. Suppose that p and d are allowed to interact with one another, in the familiar way, when a state like (i) obtains. Then it will follow, in the familiar way, from the linearity of the quantum-mechanical equations of motion, and from the stipulation that d is a properly-functioning device for the measurement and recording of the position of p , that the state of this composite system once this interaction is complete will be:

$$\alpha['A']_d[A]_p + \beta['B']_d[B]_p, \quad (\text{ii})$$

where $['A']_d$ is the state of d in which the position of d 's pointer indicates that the outcome of the measurement of the position of p is ' A ', and $['B']_d$ is the state of d in which the position of d 's pointer indicates that the outcome of the measurement of the position of p is ' B '.

And consider how it is that Bohmian Mechanics manages to guarantee that, in circumstances like (ii), the positions of the Bohmian corpuscles that make up the pointer of d are properly and reliably correlated with the position of the Bohmian corpuscle p – the position (that is) of the Bohmian corpuscle whose position has just now been *measured*. Note (in particular) that that correlation depends crucially on

Let's have a look at exactly how that works. Start with a single, structureless, particle – call it p – and two boxes. One of the boxes is called A , and is located at the point $(x = +1, y = 0, z = 0)$, and the other is called B , and is located at the point $(x = -1, y = 0, z = 0)$.¹¹ And let $[A]_p$ be the state of p in which p is located in A . And let $[B]_p$ be the state of p in which p is located in B . And suppose that at $t = 0$, the state of p is

$$(1/\sqrt{2})[A]_p + (1/\sqrt{2}) [B]_p. \quad (8)$$

Now, states like the one in (8) famously resist any interpretation as situations in which p is either in box A or in box B . And what famously *stands in the way* of such an interpretation is the fact that if we open both boxes, when a state like (8) obtains, then the subsequent observable behaviors of the particle – the probabilities (for example) of finding the particle at this or that point in space – are in general going to

the fact that the wave-function in (ii) vanishes in those regions of the configuration-space of the composite system consisting of p and d in which precisely those correlations do not obtain. And note (moreover) that it must vanish in those regions without vanishing throughout those regions of that configuration-space in which p is located in A , and without vanishing throughout those regions of that configuration-space in which p is located in B , and without vanishing throughout those regions of that configuration-space in which d 's pointer is located in 'A', and without vanishing throughout those regions of that configuration-space in which d 's pointer is located in 'B'. And note (and this, finally, is the heart of the matter) that the previous two sentences can only simultaneously be true of a wave-function (like the one in (ii)) in which p and d are quantum-mechanically *entangled* with one another – note (that is) that the previous two sentences can only simultaneously be true of a wave-function which (like the one in (ii)) cannot be represented as a function over the points of any three-dimensional arena.

¹¹ In order to keep things as simple as possible, we will treat these boxes not as physical systems, but (rather) as externally imposed potentials – and we will treat the openings and closings of those boxes not as dynamical *processes*, but (rather) as *variations* in those externally imposed potentials with time.

be very different from the behavior of a particle released from box A, and very different (as well) from the behavior of a particle released from box B, and very different (as well) from anything along the lines of a probabilistic sum or average of those two behaviors.

And all of this, as I mentioned above, can be explained, in the context of Bohmian Mechanics, by means of a story about what things are physically like, at various different times, at various different points in the familiar, material, 3-dimensional space of our everyday empirical experience of the world. The particle itself starts out in either box A or box B – but its wave-function, its so-called pilot-wave - is non-zero (when a state like (8) obtains) in both boxes. And so, when the boxes are opened, and the two branches of the wave-function flow outwards, and fill up the three-dimensional space around them, and overlap with one another, they interfere – and that interference observably affects the motion of the particle that those two branches, together, are guiding.

And the puzzle (again) is that measuring the position of a particle like that somehow makes one or the other of those branches go away. And the question is *how*. The question (to put it as naively and as literally and as flat-footedly as one can) is *where*, exactly, that other branch *goes*.

Consider (then) a radically simplified stand-in for a measuring-device – call it M - which consists (just as in the case we considered before) of a single structureless

particle, and which is constrained (we will suppose) to move along the X-axis. And let $[\text{ready}]_M$ be the state of M in which M is located at the point $(x = 0, y = 0, z = 0)$, and let $['A']_M$ be the state of M in which M is located at $(x = +1/2, y = 0, z = 0)$, and let $['B']_M$ be the state of M in which M is located at $(x = -1/2, y = 0, z = 0)$. And suppose that the kinetic term in the Hamiltonian of M happens to be identically zero. And suppose that there is an interaction between M and p, which we can switch 'on' and 'off' as we please, and which (when it's switched 'on') produces (over the course of, say, the ensuing second) evolutions like this:¹²

$$[\text{ready}]_M[A]_p \text{ ----} \rightarrow ['A']_M[A]_p \text{ and } [\text{ready}]_M[B]_p \text{ ----} \rightarrow ['B']_M[B]_p \quad (9)$$

When the interaction is switched 'on' (then) M will function, at least under the sorts of circumstances envisioned above, as a measuring-instrument for the position of p.

Note that whereas the space of the elementary physical determinables of a single structureless quantum-mechanical particle p is *three*-dimensional, the space of the elementary physical determinables of the *composite* quantum-mechanical system consisting of p and M – call that F_{pM} – is going to be *four*-dimensional. We can assign unique addresses to points in that arena using the three co-ordinates

¹² Here again, just to keep things simple, we are going to treat the business of turning this interaction 'on' and 'off' not as a variation in any dynamical degree of freedom, but (rather) as a variation in an externally imposed effective Hamiltonian. None of these simplifications – as the reader can easily confirm for herself – involves any loss in generality.

(call them x_p , y_p , and z_p) that correspond to the parochial three-dimensional 'position of p' and one more (call it x_M) that corresponds to the parochial one-dimensional 'position of M'.

Suppose that we initially that prepare composite system in the state

$$[\text{ready}]_M \left(\frac{1}{\sqrt{2}} [A]_p + \frac{1}{\sqrt{2}} [B]_p \right), \quad (10)$$

with the interaction switched 'off', and then open the boxes. In this case, the M remains completely unentangled with p, and once the boxes are opened, one branch of the wave-function of the composite system will spread outward from the point $(x_p = +1, y_p = 0, z_p = 0, x_M = 0)$, and the other branch will spread outward from the point $(x_p = -1, y_p = 0, z_p = 0, x_M = 0)$, and each of them will fill up the three-dimensional hypersurface $x_M = 0$ of the determinable space of the composite system, and they will overlap with one another, and interfere with one another, and both of them will contribute to determining the Bohmain trajectory of the world-particle. (And note that all this – except for the presence of the world-particle itself – is exactly analogous to what was going on in the system described by the Hamiltonian in equation (7) when particles 2 and 4 are both at the origin)

If (on the other hand) we initially prepare the composite system in the state in (8) with the interaction switched 'on', then it will follow from (9), together with

the linearity of the quantum-mechanical equations of motion, that the state of $p+M$ will become

$$(1/\sqrt{2})[|A'\rangle_M|A\rangle_p + (1/\sqrt{2})|B'\rangle_M|B\rangle_p \quad (11)$$

Now M and p are maximally entangled with one another, and if the boxes are opened at this point, then one branch of the wave-function of the composite system will spread outward from the point $(x_p = +1, y_p = 0, z_p = 0, x_M = +1/2)$, and fill up the three-dimensional hypersurface $x_M = +1/2$, and the other branch will spread outward from the point $(x_p = -1, y_p = 0, z_p = 0, x_M = -1/2)$, and fill up the three-dimensional hypersurface $x_M = -1/2$, and the two will not overlap with one another, and will *not* interfere with one another, and only one of them – the one that's non-zero on the hypersurface where the world-particle happens to be located – will contribute to determining the trajectory. And the reader should note that it is absolutely critical to the way all this works – it is absolutely critical (in particular) to the very idea of an *entangling* of the measuring-device with the measured particle – that the dimension of the determinable space along which the wave-function spreads out when M is in motion is *orthogonal* to all of the dimensions of that space in which the wave-function spreads out when p is in motion. (And note that *this* – except (again) for the presence of the world-particle itself – is exactly analogous to what was going on in the system described by the Hamiltonian in equation (7) when the attractive potential is switched on)

And so the answer to the question of where the other branch goes, when we measure the position of p , is literally, and flat-footedly, that *it gets pushed off into another dimension*. And this (in microcosm) is the sort of thing that happens *whenever* we do measurements on quantum-mechanical systems. What's strange about quantum mechanics, what makes it look like magic, even in a case as simple as that of a single structureless particle, is that the three-dimensional space of ordinary material bodies is too small to contain the complete microscopic history of the world.

And much the same sort of thing is true on the GRW theory. This may seem, at first, like a puzzling claim. The reader may want to object that what happens on the GRW theory is not that one of the branches gets 'pushed off into another dimension', but (rather) that one of the branches simply *disappears*. But consider the *mechanism* of that disappearance. The wave-function of the world, which is a function of position in the space of elementary physical determinables, is multiplied by another function, the so-called 'hitting' function – which is *also* a function of position in the space of elementary physical determinables. And this multiplication of the wave-function by the hitting function somehow manages to leave one of the above branches of the wave-function intact, and causes the other one to vanish. And that can only occur if these two branches of the wave-function, which overlap everywhere in the 3-dimensional space of ordinary material bodies, somehow manage *not* to overlap *anywhere* in the space of elementary physical determinables. And *that* can only occur if the space of elementary physical determinables has at

least one more dimension than the space of ordinary material bodies – and if the two branches have somehow become separated from one another along that additional dimension.

And the reader can confirm for herself that much the same thing would be true, as well, on the many-worlds interpretation of quantum mechanics – if the many-worlds interpretation were not otherwise incoherent.

And so, at the end of the day, there *does* seem to be an intimate and invariable connection between the coming-apart of the space of ordinary material things and the space of elementary physical determinables (on the one hand) and everything that's exceedingly and paradigmatically *strange* about quantum mechanics (on the other). Quantum-mechanical sorts of behavior seem to *require* that the space of the elementary physical determinables is bigger than the space of ordinary material things – and whenever the space of the elementary physical determinables space *is* bigger than the space of ordinary material things, quantum-mechanical sorts of behavior seem to quickly ensue. And it begins to look as if what we have stumbled across here is (indeed) a *diagnosis*, or an *explanation*, of the fact that the world is quantum-mechanical.

Let's see where all this leaves us.

The fact that the space of the elementary physical determinables of the world and the space of the ordinary material bodies of the world are conceptually *distinct* from one another – the fact that there is no a priori reason whatever why they should *coincide* with one another, or have the same *topology* as one another, or have the same *dimensionality* as one another – is a purely *logical* point, a point which might in principle have been noticed, by means of purely conceptual analysis, long before the empirical discoveries that gave rise to quantum mechanics. And we have seen how easy it is, merely by playing around with the simplest imaginable Hamiltonians of classical Newtonian particles, to stumble onto physical systems for which the space of the elementary physical determinables has a different number of dimensions than the space of ordinary material bodies. But (as I have already remarked) there is nothing mysterious or surprising about this distinction's having in fact gone unnoticed as long as it did. It is (after all) a fundamental principle of the Manifest Image of the World – and *all the more so* (indeed) because we are not even aware of ever actually having *adopted* it – that the material space of the world and the determinable space of the world are exactly the same thing. And that principle has since been endorsed, and further fortified, in the course of scientific investigation, by Newtonian Mechanics, and by Maxwellian Electrodynamics, and by the Special and General theories of Relativity, and even (in so far as these can be considered in isolation from quantum mechanics) by the high-dimensional geometries of string theory, and (indeed) by the entire edifice of classical physics.

You might even say that the principle that the material space of the world and the determinable space of the world are exactly the same thing is the very *essence* of the classical picture of the world, and the simplest and most illuminating way of pointing to what sets it apart from quantum mechanics.

But the relationship between the material space and the determinable one is (for all that, and for the Nth time) an obviously *contingent* matter. And one of the lessons of the simple exercises we have been working our way through here is that *the moment that we take that in*, the moment that we even *raise the question* of what the world might be like if those two spaces *differed* from one another, something paradigmatically quantum-mechanical just flops right out. And it seems fair to say that if the conceptual distinction between material space of the world and the determinable space of the world had made itself clear to anybody (say) a hundred and fifty years ago, then the 20th century physics of sub-atomic particles might have amounted to less of a shock than, in fact, it did – it seems fair to say (that is) that the *elucidation* of the conceptual distinction between the material space of the world and the determinable space of the world offers us a way of looking at quantum mechanics as something natural, and beautiful, and simple, and understandable, and maybe even to be expected. Indeed, in the light of the sorts of considerations that we have been through here – the *Classical* case is the one that looks exceptional, and conspiratorial, and surprising.

None of this (mind you) seems to me point in the direction of any *different* or *deeper* or more *general* or more *fundamental* theory from which quantum mechanics might imaginably be *derived*.

If what I have been attempting here succeeds, then what it does for quantum mechanics is (rather) something along the lines of what Minkowski did for Special Relativity: It takes a finished and well-formulated fundamental physical theory – a theory which is in no strictly *logical* or *empirical* need of any further elaboration – and offers us a crisp and elegant and profound way summing up what the theory is telling us about the world, a way of saying what the theory *means*, a way of isolating (you might say) its *essence*. And what I take myself to be proposing here is an account of the *essence* – in exactly the sense just described – of *quantum theory*.

*

Here's another way to put it:

What I take myself to be proposing here is a better and more straightforward and more intuitive way of *teaching* quantum mechanics. The idea (in a nutshell) is that it helps to picture the concrete fundamental physical *stuff* of the world as floating around in something other, and larger, and more fundamental, than the space of ordinary material bodies – because picturing things that way makes it easy to see why everything looks so odd, and why it looks odd in a paradigmatically

quantum-mechanical sort of way, from the *point of view* of the space of ordinary material bodies.

Of course, the observation that it helps to *picture* things in a certain way doesn't settle any questions, in and of itself, about how things actually *are*. But it isn't *irrelevant* to such questions either. And what it *suggests*, I think, is that any attempt at insisting on the contrary, any attempt (that is) at insisting that the habitation of the concrete fundamental physical stuff of the world is the familiar 3-dimensional space of ordinary material bodies, any attempt (for example) at thinking about the quantum-mechanical wave-function as something merely *nommic*, or as some incredibly complicated kind of a *property* of ordinary material particles, or as a *multi-field*, or what have you, is likely to come at a steep cost in terms of *explanation* and *understanding*.

What we saw in the early sections of this paper was that a pair of concrete point-like physical items, floating around in a 2-dimensional space, in accord with a simple, classical, local Hamiltonian like the one in equation (6), can give rise to paradigmatically quantum-mechanical weirdness in an emergent one-dimensional space of ordinary material bodies. The ordinary material "shadows" of those items move around in the one-dimensional space as if they were interacting with one another non-locally, and collide with one another, or fail to collide with one another, according to rules that cannot be written down in terms of their intrinsic physical

properties, and seem to be organized into parallel possible worlds or scenarios that can nevertheless *interfere* with one another, and so on.

On a “primitive ontological” version of a world like this one, all that there really actually ontologically *is* are ordinary material particles in the one-dimensional space – and we are offered nothing along the lines of an *explanation* of the behaviors of those particles *at all*. The fact that those particles behave in the baroque and astonishing ways that they do - the fact that they behave (that is) *as if* they were shadows of a concrete point-like physical items floating around in a two-dimensional space – is stipulated to be a matter of fundamental physical law. Period.¹³

And on a “multi-field” version of a world like this one, the elementary and indivisible and not-further-analyzable concrete physical items of the world of the world – or some of them, at any rate¹⁴ - are supposed to be located, in a way that resists any straightforward attempt at visualization, at *pairs* of points in the fundamental one-dimensional physical space of the world.

¹³ The details of a “primitive ontological” version of a world like this one are going to depend, of course, on exactly how we end up solving the measurement problem. On a primitive ontological version of Bohmian Mechanics (for example) there are going to be two ordinary material particles floating around in the one-dimensional space, whereas on a primitive ontological version of a Many-Worlds theory there will be four, and on a primitive ontological version of a theory of the collapse of the wave-function, there will be four, two of which eventually go away.

¹⁴ Here again – as in footnote 13 – the details are going to depend on exactly how we end up solving the measurement problem.

But if we imagine that the fundamental concrete physical stuff of a world like this one is actually floating around in the *two*-dimensional space, then the strange and complicated one-dimensional appearances can be understood, in the manner of all of the best and deepest and most satisfying scientific explanations we *have*, in terms of a simple and literal and mechanical picture – the sort of picture (that is) that one can draw on a piece of paper - of what's going on *underneath the surface* of those appearances. And exactly the same sorts of considerations can be applied to the full mathematical formalism of quantum mechanics, and to any of the various solutions that have been proposed to the measurement problem.